

Centec Premier Soft Close Installation Guide

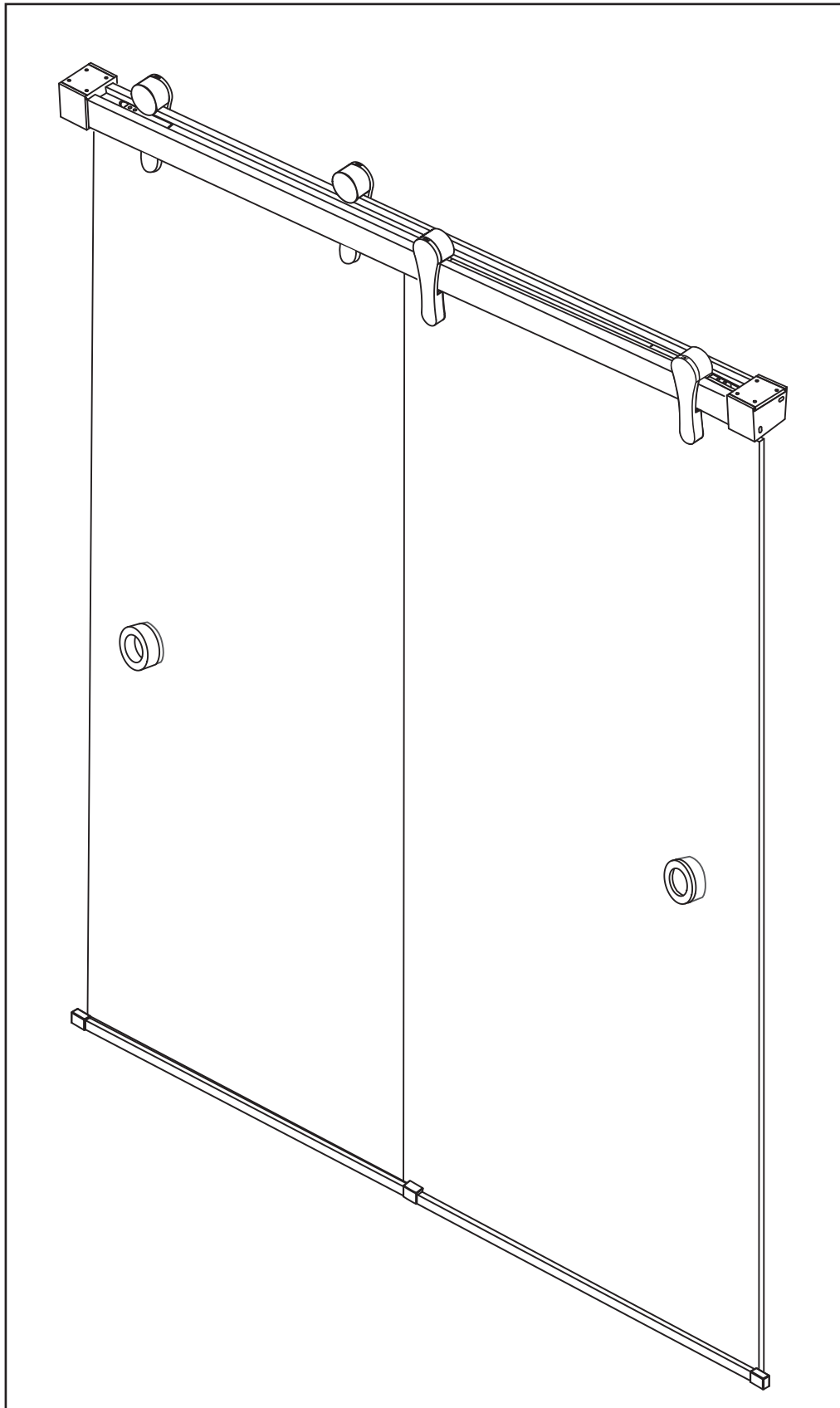

Centec Premier

Detailed diagram of Premier components

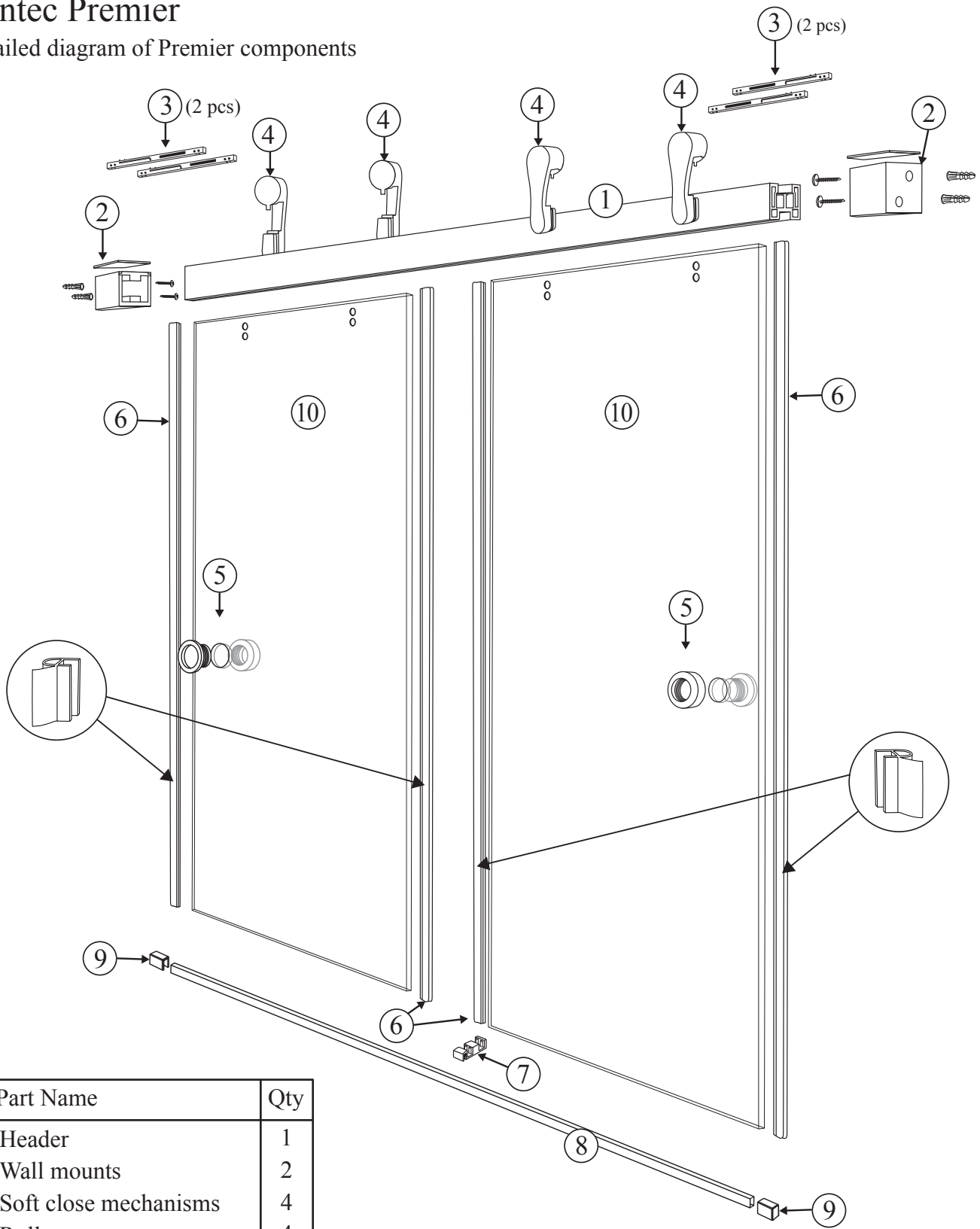

#	Part Name	Qty
1	Header	1
2	Wall mounts	2
3	Soft close mechanisms	4
4	Rollers	4
5	Cup handle assembly	2
6	Vinyls	4
7	Guide	1
8	Water dam	1
9	Threshold caps	2
10	Glass doors	2

Centec Premier

Tools required

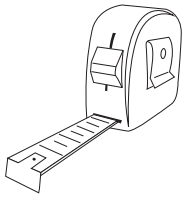

Tape Measure



Level

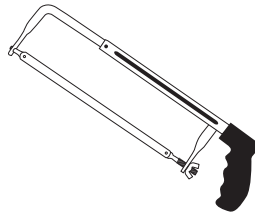

Hacksaw
(or Chopsaw w/metal blade)



Safety glasses

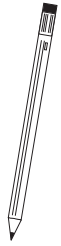

Pencil/Marker



Drill bit
3/16" carbide masonry

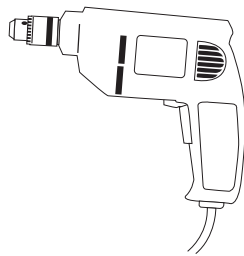

Drill



Phillips head
screwdriver

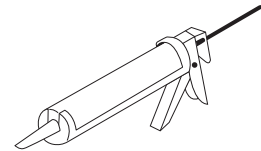

Caulk gun

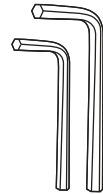

Allen wrenches
(in package)

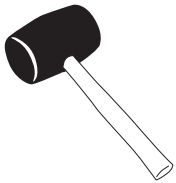

Rubber mallet



Masking tape

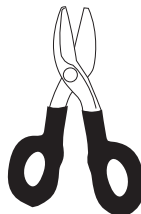

Scissors

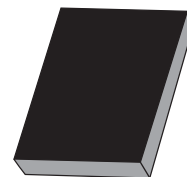

Glazing block
piece of wood (2"x 4")

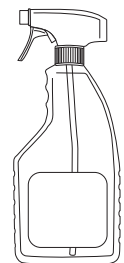

Glass cleaner



WARNINGS

- **Before starting, please read instructions carefully and thoroughly; then proceed step by step.
- **Please wear safety glasses and safety gloves whenever drilling or cutting tile or handling metal/glass parts.
- **When drilling through tile, carefully break through glazed surface only with sharp tool and then drill slowly.
- **Wall uprights must be installed level and plumb. Do not follow grout lines.
- **To insure complete customer satisfaction Century Bathworks recommends installation by a professional.
- **Risk of injury or product damage. Two people should perform this installation.
- **Do not cut the top and bottom track the same length for this installation.
- **Please carefully unpack all parts for your unit as listed on previous page and also check that you have all the tools as listed above.
- **If any parts are missing or damaged, please contact Century Bathworks or your dealer for replacements.

- 1) Place slow close mechanisms into header on both sides of the header, keeping them close to the wall brackets. Lightly tighten the set screws so they don't move.
- 2) Top of header bracket should be even with the height of unit ordered. Place header bracket on wall and mark hole locations for mounting screws. Make sure brackets are plumb and level and in line with each other. Top of header bar should be 3/16" lower than height of unit ordered.
- 3) Drill 3/16" holes in walls with masonry drill bit. Install plastic anchors in holes and screw header brackets to walls.
- 4) Place header into wall brackets (Header rail has been cut to size).
- 5) Measure bottom opening and cut water dam 1/4" to 3/8" shorter than the size measured. Cut off of each end to keep bottom guide centered in the opening.
- 6) Using a level line - line up the front of the header with the front of the water dam, making sure each side of the water dam is in line with the header. Mark the location of the water dam on the base, then peel the covering on the double sided tape off and apply to the base along the lines you marked. Make sure each end is equal distance from each wall. Place bottom guide onto the water dam where notch is cut into water dam – then press onto water dam until guide touched the base.
- 7) Place 2 roller carriages on the inside top of header.
- 8) Place shims or blocks on base and place sliding glass door into inside slot of bottom track on top of shims. Lift glass door up and attach roller carriages with glass attachment screws. Snug screws but do not tighten screws. Repeat with outside door. Once both doors are attached to roller carriages, then remove shim and blocks from base.
- 9) Cut vinyl bumpers to fit height of glass doors and place on each side of both doors.
- 10) Slide glass doors to walls and adjust glass doors to fit opening in both height and width using the height adjustment screws on each roller carriage. Tighten glass attachment screws on all roller carriages.
- 11) Place cup handles on each door. Making sure doors do not hit cup handles when sliding them side-to-side.
- 12) Silicone both sides of water dam and bottom guide – making sure double sided tape is well protected from moisture.
- 13) Place water dam end caps on each end of water dam and silicone into place.
- 14) Adjust slow close mechanism so that each door catches mechanism on each end of header. The slow close mechanism should be about 3" from the wall. Slide each door side-to-side to make sure slow close mechanism engages and tighten set screws.
- 15) Place roller carriage screw covers in place.
- 16) OPTIONAL: Place wall bracket caps onto wall brackets and tighten in place.

1

Soft close mechanisms (4)

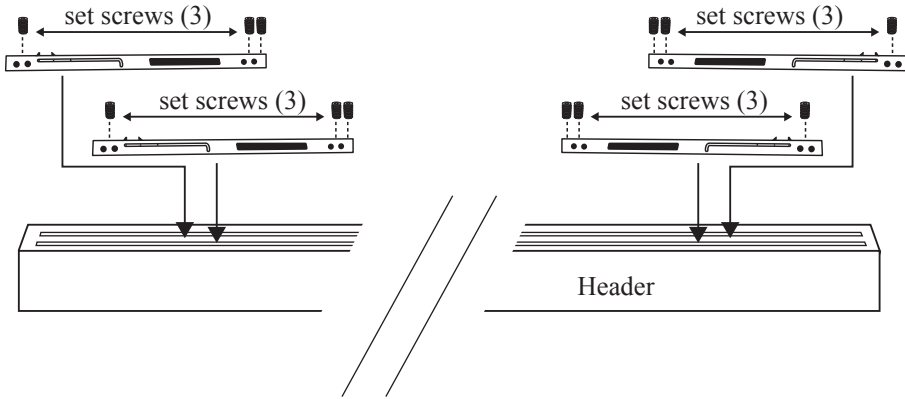

2

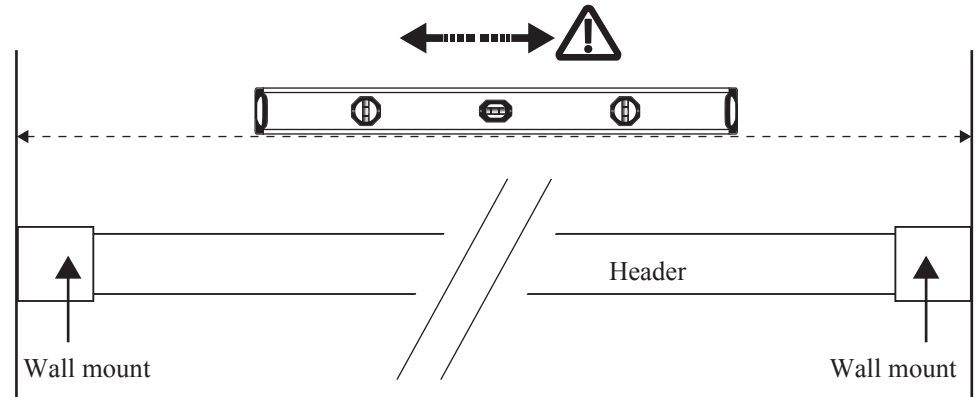

3

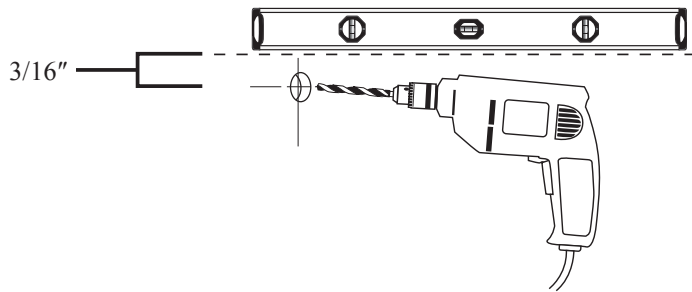

4

Place the header (that is trimmed to opening size) into wall brackets.

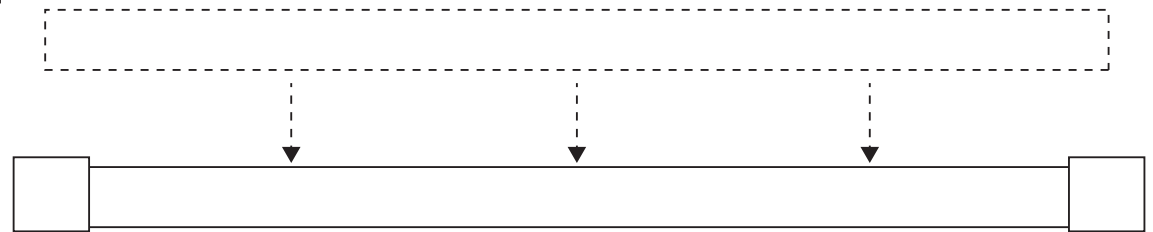

5

Trim 1/4" to 3/8" shorter than the opening size measured.

Center door guide between walls.

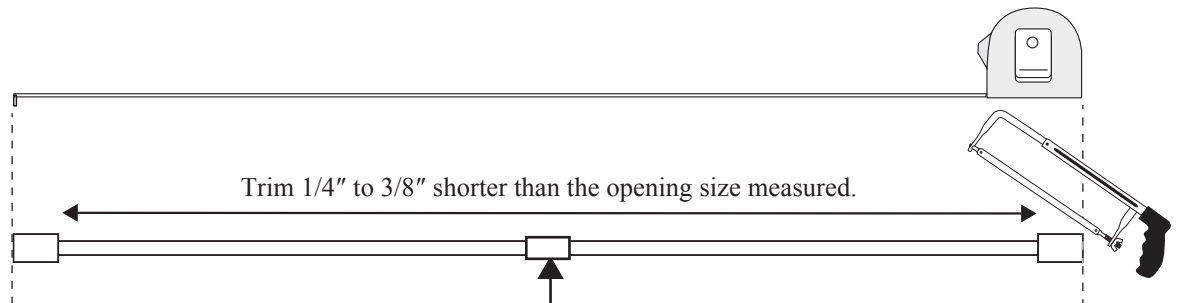
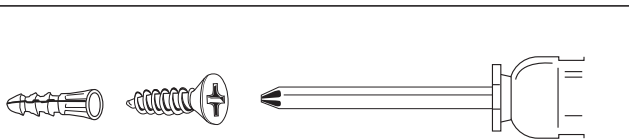

6

Header cap plates can be used to lock header into wall brackets. They are optional.

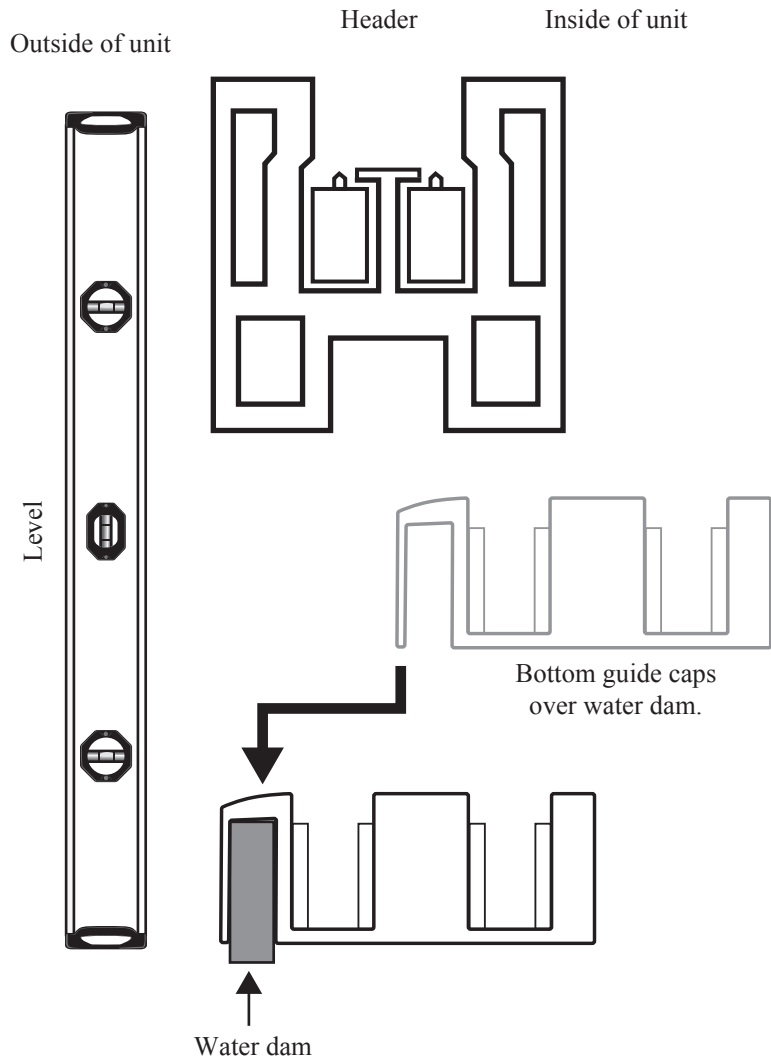

7

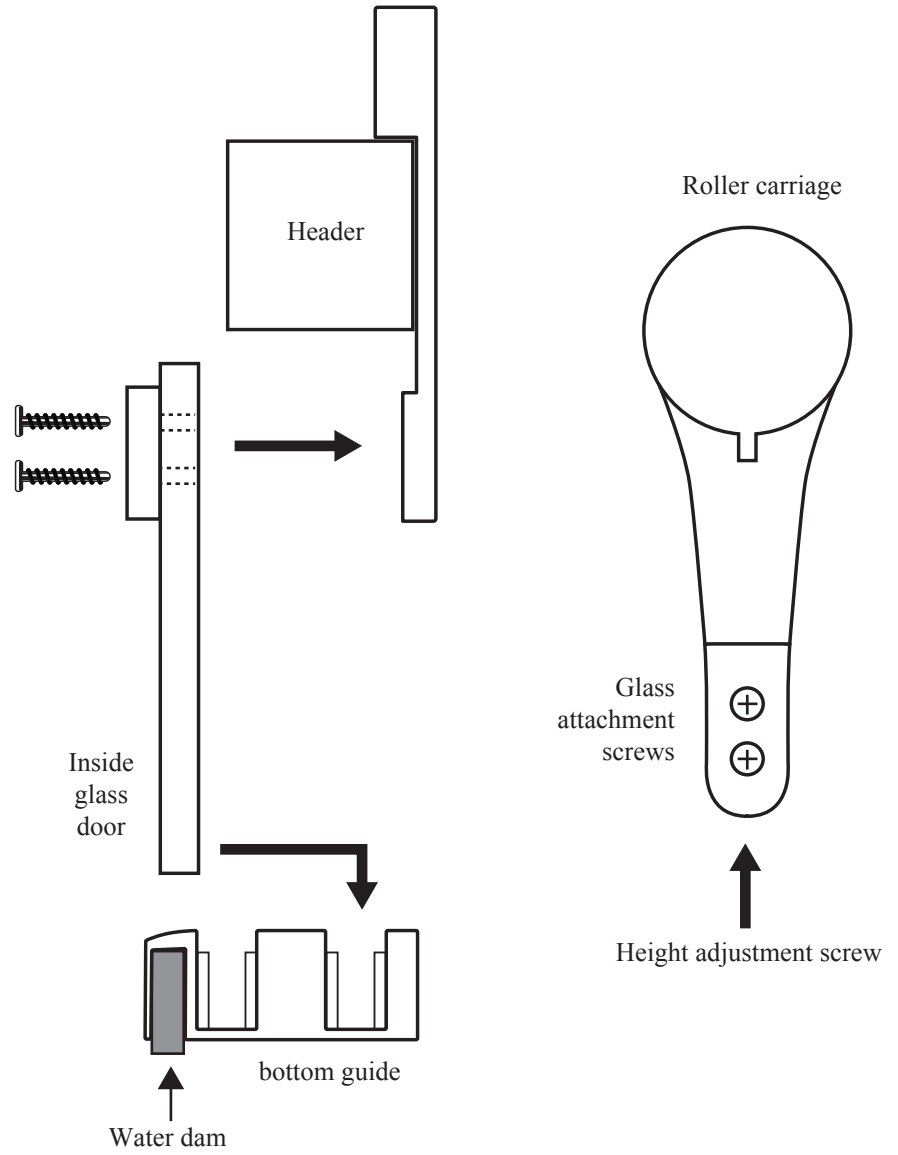

8

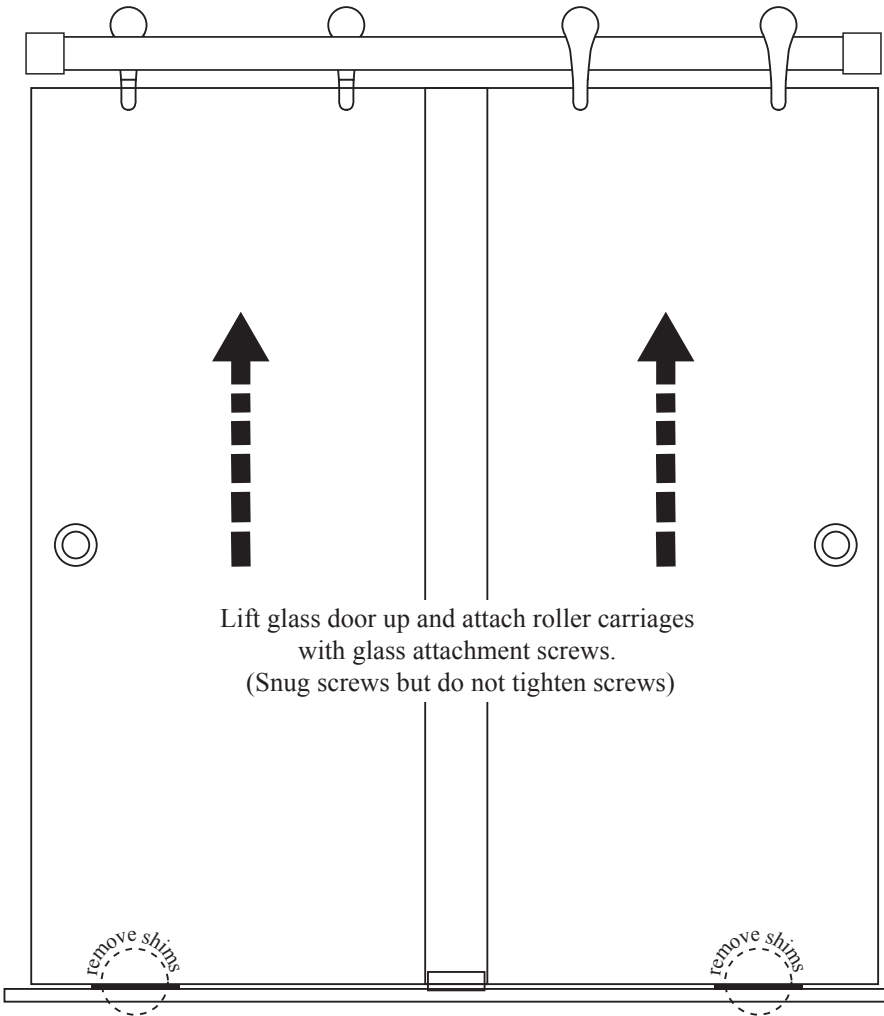

Once both doors are attached to roller carriages, remove shims from base.

9

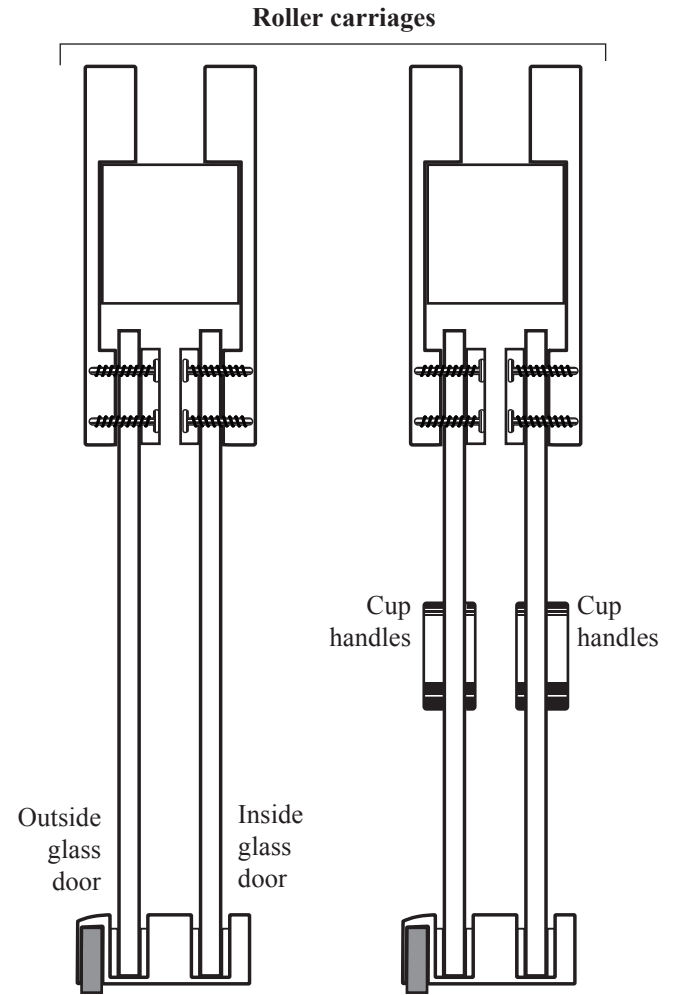

10

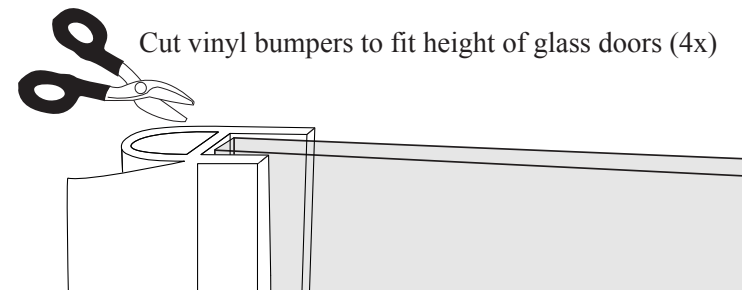

11

Cup handles (2x)

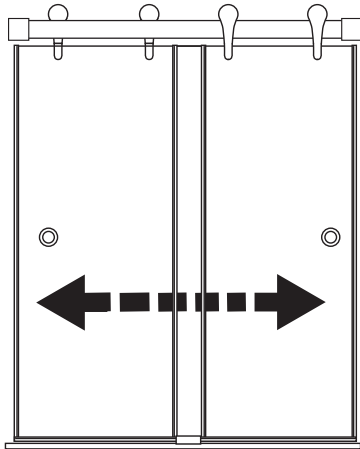
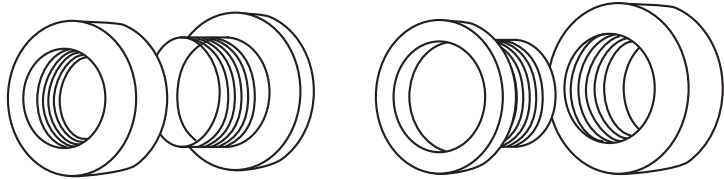

Confirm sliding doors do not contact cup holders

12

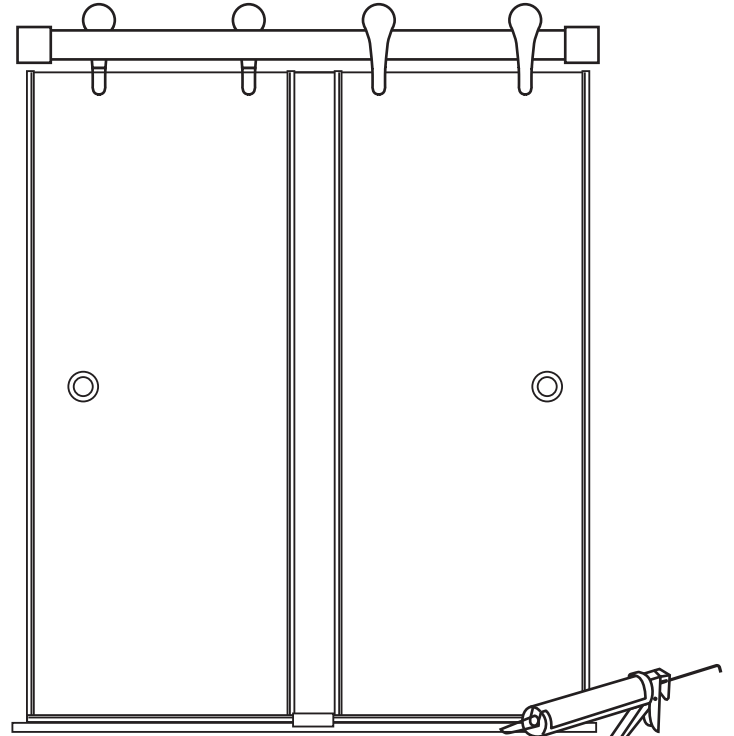

Silicone bottom guide

13

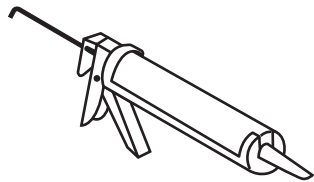

Water dam end caps (2x)

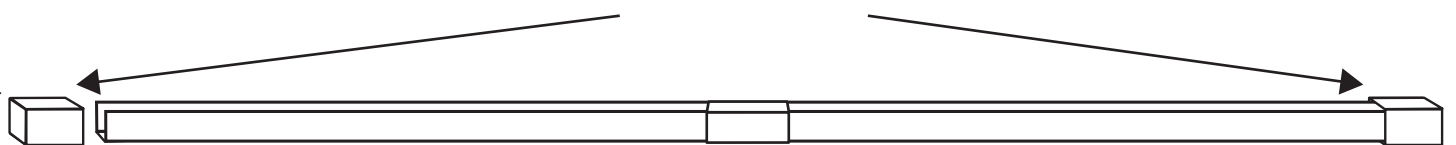

Guide centered on base

14

Adjust slow close mechanism for
each door (about 3" from the wall)
When correctly set, tighten set screws

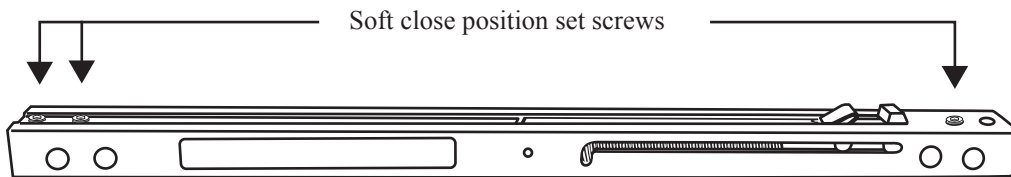
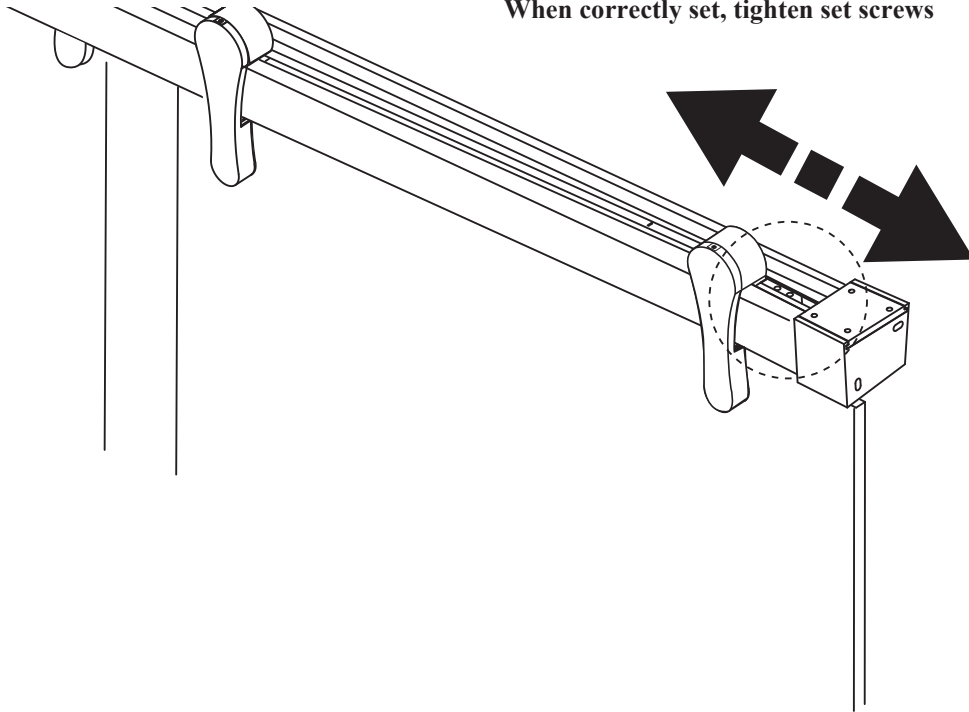

15

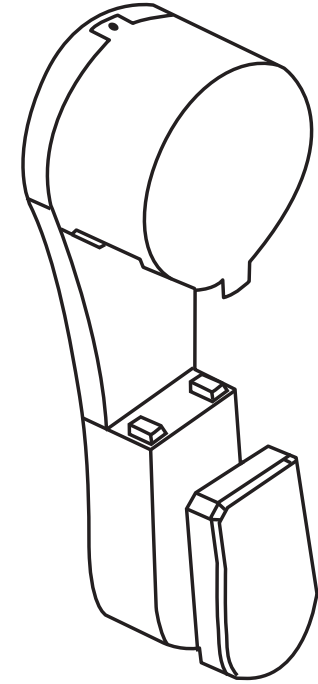

Roller carriage cap

16

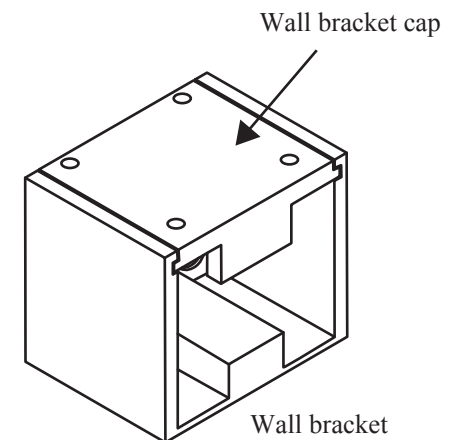

Wall bracket