



**Installation of Model 1530-4-BL-F-0-R-E-CB Shown.**

**"For Household/Residential Use Only"**

Installation Instructions  
**Medicine Cabinet**

**IMPORTANT SAFETY INSTRUCTIONS**

**WARNING-** To reduce the risk of burns, fire, electric shock, or injury to persons:

1-Use this furnishing only for its intended use as described in these instructions. Do not use attachments not recommended by the manufacturer.

**All Electrical Connections Should be Made By A Licensed Electrician**

**SAVE THESE INSTRUCTIONS**

IF YOU NEED REPLACEMENT PARTS OR HAVE INSTALLATION QUESTIONS, PLEASE CALL OUR CUSTOMER SERVICE REPRESENTATIVES.  
**800-524-2578**  
 Monday -Friday 8:00 am-4:30 pm EST

- PARTS LIST-1530 CABINET**  
 (See back cover for parts list of other cabinet sizes)
- 1- 1530 "E"Option Cabinet
  - 2- 1530 Door (Note: DO NOT REMOVE DOOR FROM PROTECTIVE CARTON UNTIL INSTALLATION OF DOOR)
  - 3- Glass Shelves 5/16" Thick (3)
  - 4- Mounting Bracket (For Surface Mount) (1)
  - 5- Surface Mount Top Z Clips (2)
  - 6- Hole Plugs (32)
  - 7- Clear Shelf Clips (12)
  - 8- Screw Head Cover Caps (12)
  - 9- Wood Screws # 10 x 1 1/2" (5)
  - 10- Plastic Wall Anchors (5)
  - 11- Cabinet Connectors (2)
  - 12- # 10-32 x 1/2" Machine Connector Screws (8)
  - 13- Name Plates
  - 14- 130 Deg Limit Clips (2)

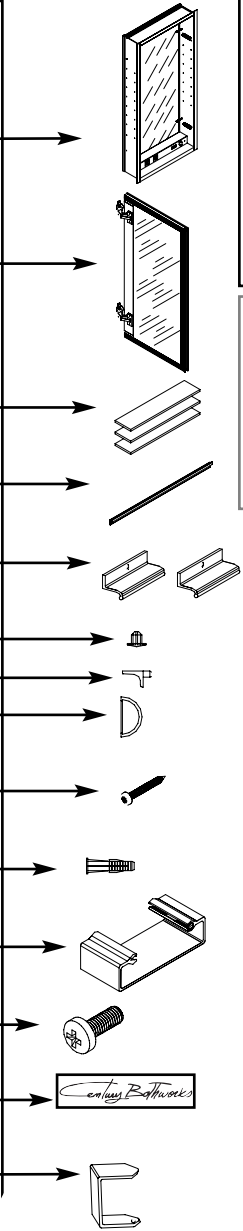

**GROUNDING INSTRUCTIONS**

This product must be connected to a grounded metal, permanent wiring system, or an equipment-grounding conductor must be run with the circuit conductors and connected to the equipment terminal or lead on the product.

**General Notes**

- 1-Open Cabinet box and remove boxed door. Do not remove boxed door from its carton until installation of door is required.
- 2-Check box thoroughly for all hardware and any loose parts.
- 3-A square and Plumb Installation insures proper operation of Door.
- 4-Improper installation voids the warranty. Installed cabinets cannot be returned.

Limited Warranty One Year Term

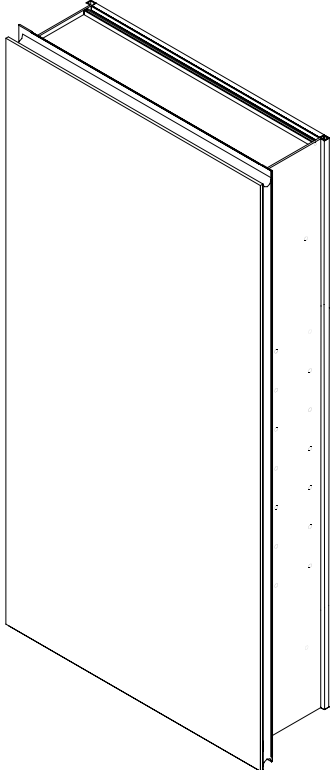

Century Bathworks, Inc.™  
 250 Lackawanna Ave, West Paterson. NJ 07424  
 973-785-4290 800-524-2578 Fax 973-785 0777  
 www.centurybathworks.com

**IMPORTANT:**  
 To insure complete customer satisfaction Century Bathworks, Inc. recommends installation by a professional installer.

## ELECTRICAL HOOK UP AND SPECIFICATIONS

- 1- CBW CABINET WITH "E" OPTION \* USE A 120 VAC 20 AMP. GFI CIRCUIT.
- 2- UP TO 4 CABINETS CAN BE WIRED TO THE CIRCUIT.
- 3- INCLUDES TWO OUTLETS.
- 4- CABINET CONTAINS A 50 WATT DOOR HEATER
- 5- THE DOOR INCLUDED WITH THIS OPTION IS EQUIPED WITH A DISCONNECT CORD. THE DOOR HINGE ORIENTATION (L OR R) MUST BE DESIGNATED DURING THE ORDERING PROCESS.

**WARNING!**  
**"E" OPTION CABINETS  
MUST BE WIRED TO A  
20-AMP GFI CIRCUIT BREAKER  
(GROUND FAULT INTERRUPTER)  
WHEN USED IN BATHROOMS AND ALL  
OTHER LOCATIONS REQUIRED BY THE  
NATIONAL ELECTRIC CODE**

"E" Option--make the final electrical connection within the Electric Outlet Shelf as supplied pre-wired for the outlets. Be sure to close the access panel in the shelf with the screws provided. If unit is equipped with a door heater, plug into the receptacle on the Electric Outlet Shelf.

Activate the door heater from switch on outlet shelf. Within 3 minutes the center portion of the door will get warm. The center area of the mirror comprising approximately 2 square feet will provide fog free viewing. If the de-fogger does not function check wiring to the outlet shelf. **DO NOT ATTEMPT TO REPAIR THE DOOR.** There are no field serviceable parts. Contact the factory or your dealer.

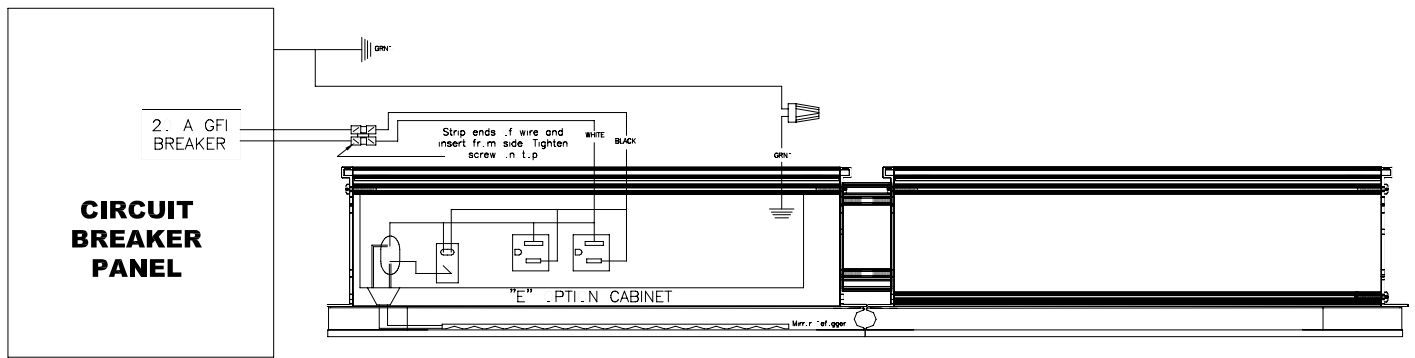

Be sure that the rough wiring is positioned correctly behind the opening or surface mount location of the cabinet for the location of the electric connection in the cabinet.

For cabinets with the "E" option-- remove the two screws on the front of the outlet shelf and attach a suitable cable clamp in the back of the panel.

The rough wire for this cabinet should extend through the cabinet at least 8" so that connections can be made.

The cabinet combination shown as typical in this manual indicates the location for electrical connections.

Connection locations for other combinations of cabinets will vary. Up to 4 cabinets can be wired to one circuit.

## TOOLS REQUIRED

For installation of your Century Bathworks cabinet the following tools will be needed.

- 1-Safety Glasses
- 2-Measuring Tape
- 3-Level
- 4-Power screw driver or a Phillips head screw driver
- 5-A # 2 Phillips head screwdriver
- 6-Electric drill
- 7-Drill bit 8mm

## ROUGH OPENING SPECIFICATIONS

Model Number	Rough Opening Single Cabinet	Rough Opening Two (2) Cabinets
	<b>WIDTH    HEIGHT</b>	<b>WIDTH    HEIGHT</b>
1524	14 1/4" X 23 3/8"	29 1/4" X 23 3/8"
1530	14 1/4" X 29 3/8"	29 1/4" X 29 3/8"
1930	18 1/4" X 29 3/8"	37 1/4" X 29 3/8"
2330	22 1/4" X 29 3/8"	45 1/4" X 29 3/8"
1540	14 1/4" X 39 3/8"	29 1/4" X 39 3/8"
1940	18 1/4" X 39 3/8"	37 1/4" X 39 3/8"
2340	22 1/4" X 39 3/8"	45 1/4" X 39 3/8"

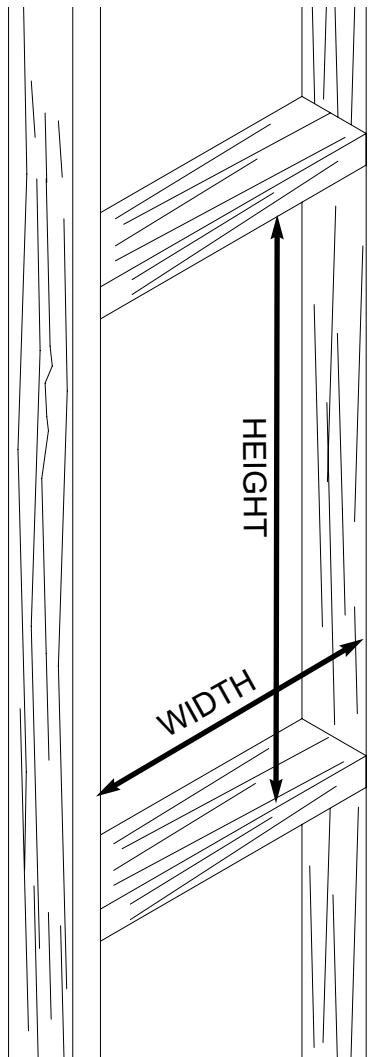

Take care in determining correct opening size.

A plumb and level opening is necessary to assure a correct installation.

**IMPORTANT:**

Locate Medicine Cabinet at correct height. Make sure there is at least 1" of clearance above any obstructions as shown below.

To insure a complete customer satisfaction Century Bathworks, Inc. recommends installation by a professional installer.

**Formula for determining Rough Opening**

Cabinet Width Minus 3/4"

**For Two or more Cabinets,** Cabinet Width Minus 3/4" Plus Second Cabinet Width

**Example** ( 15 " wide Cabinet Plus one 19" Wide Cabinet = 15" - 3/4" = 14 1/4" + 19" = 33 1/4"

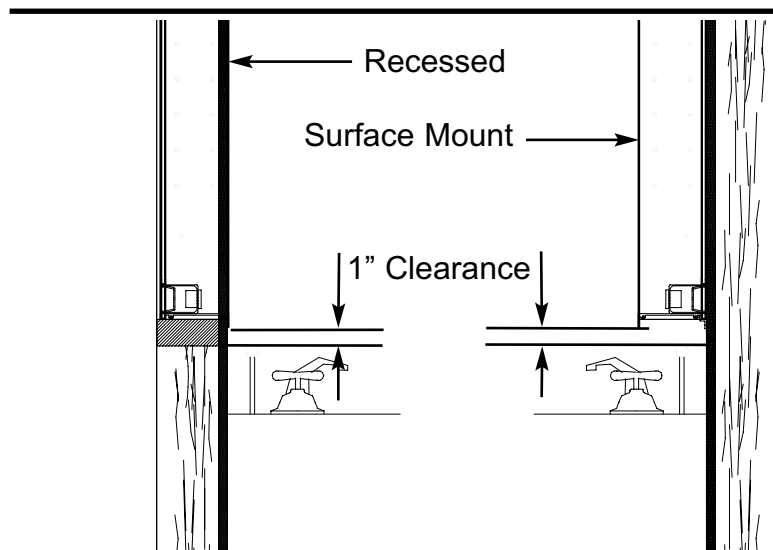

# RECESS MEDICINE CABINET INSTALLATION

Follow steps 1,2,3

Determine correct Rough Opening using Formula Provided. Make sure Opening is **PLUMB** and **LEVEL**.

Place Cabinet Box into Rough Opening. Make sure cabinet flange covers rough opening evenly all around. Shim as needed.

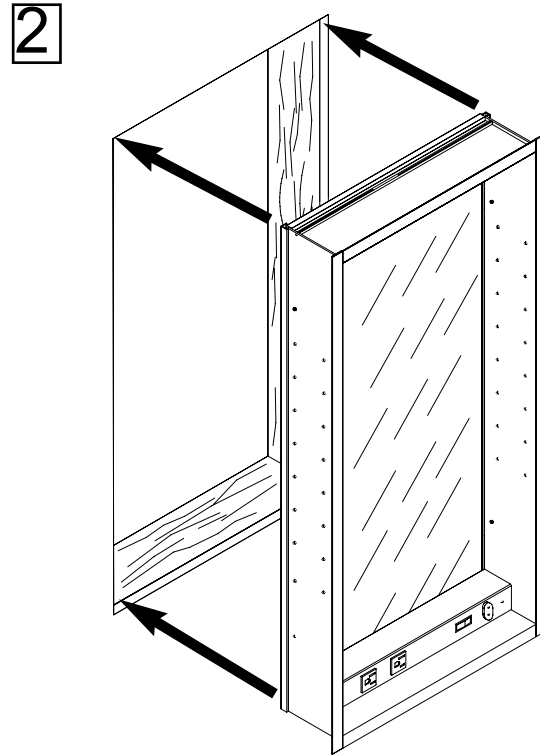
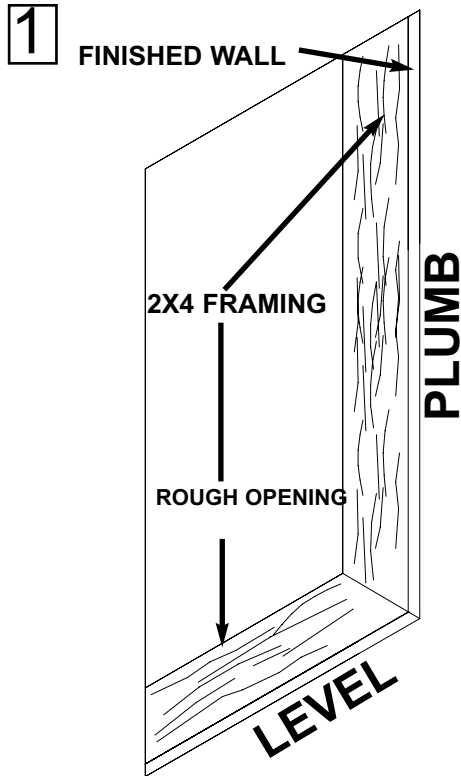

Insert (4) # 10 x 1 1/2" Wood screws Provided into four locations provided for recessed installation as shown. Be careful not to overtighten. Make sure Cabinet is centered in Rough Opening.

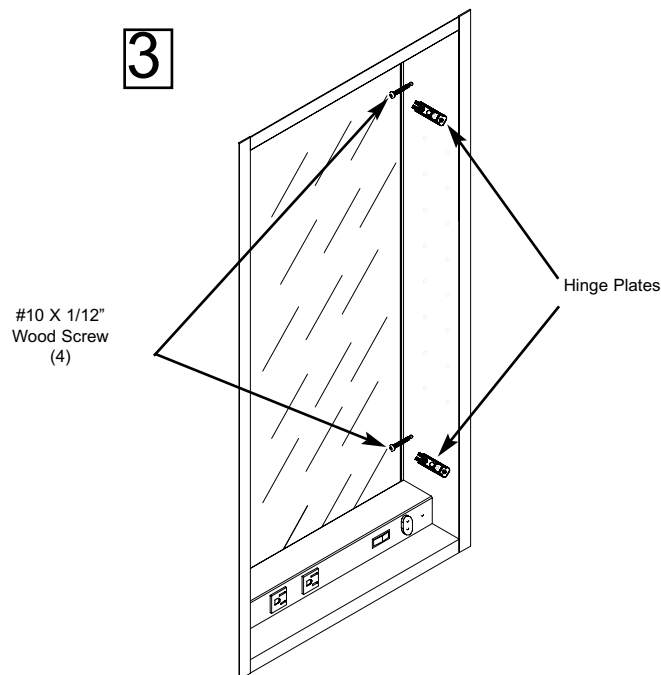

# MEDICINE CABINET INSTALLATION SURFACE MOUNT

Follow steps 5,6,7,8,

Determine correct height and draw a level horizontal line as shown in Sketch 5.

**5**

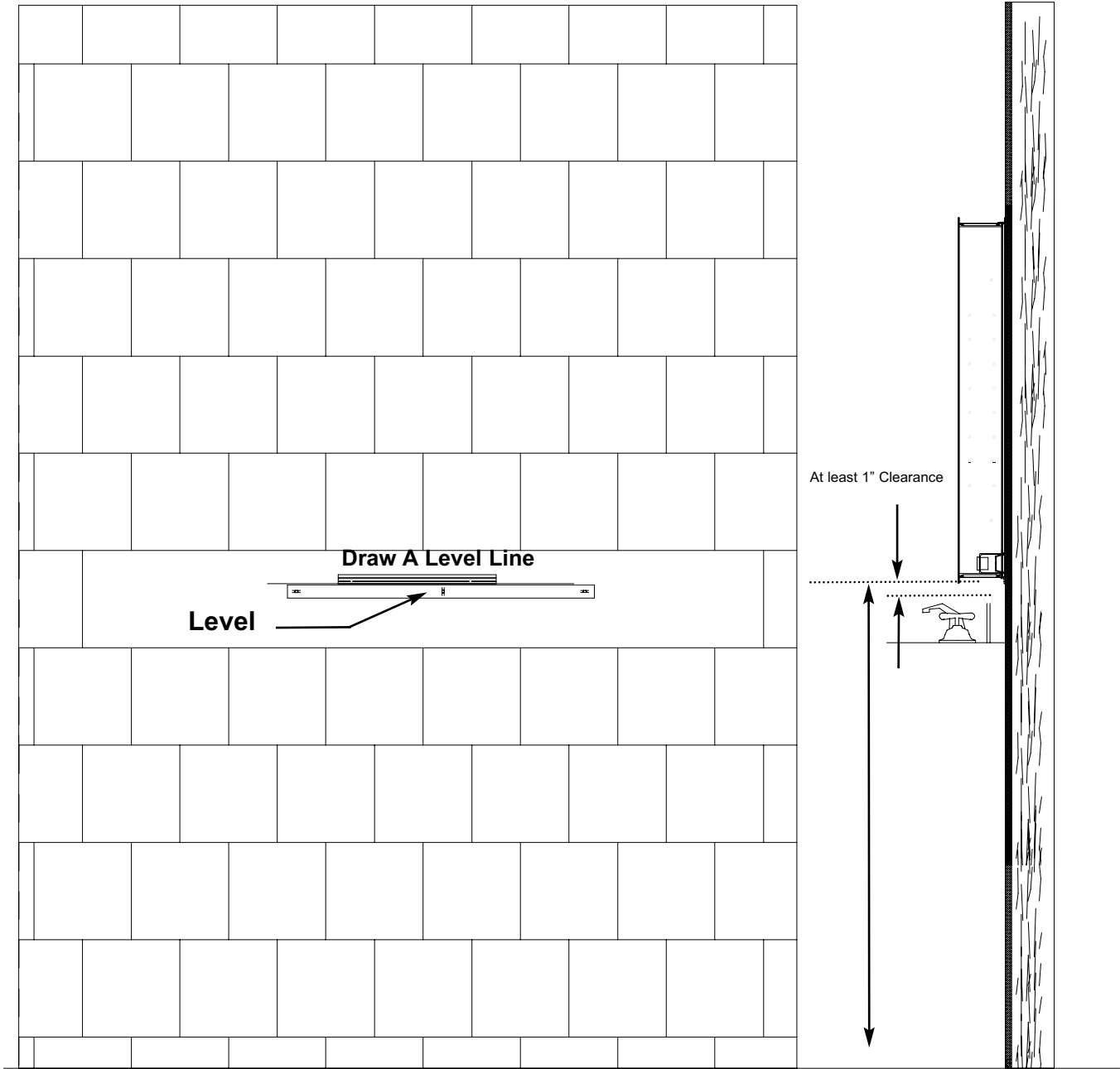

Determine hole location on Mounting Bracket as shown in Sketch 6 and drill  $7/32$ " holes. At least (2) Two locations.

6

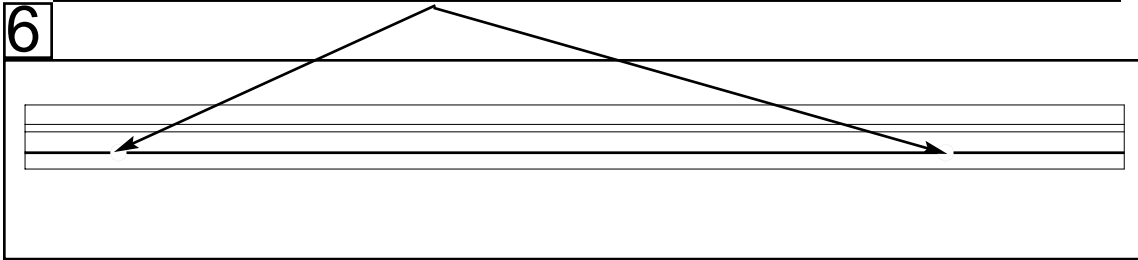

Place bottom of wall bracket on horizontal line and at correct position Left to Right and mark hole location as shown in Sketch 7.

7

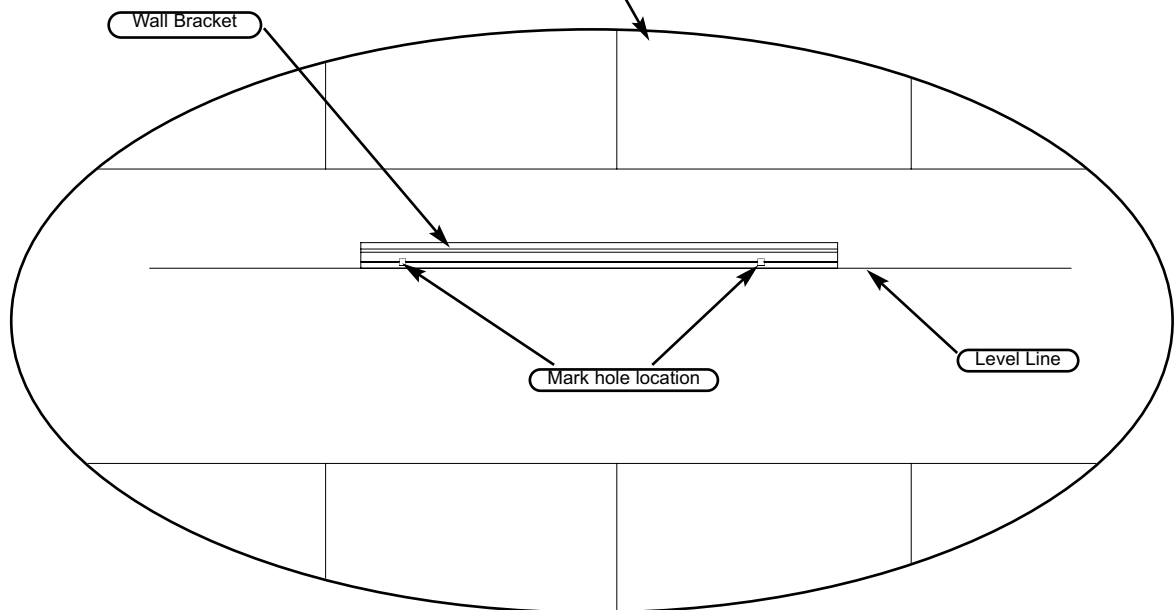
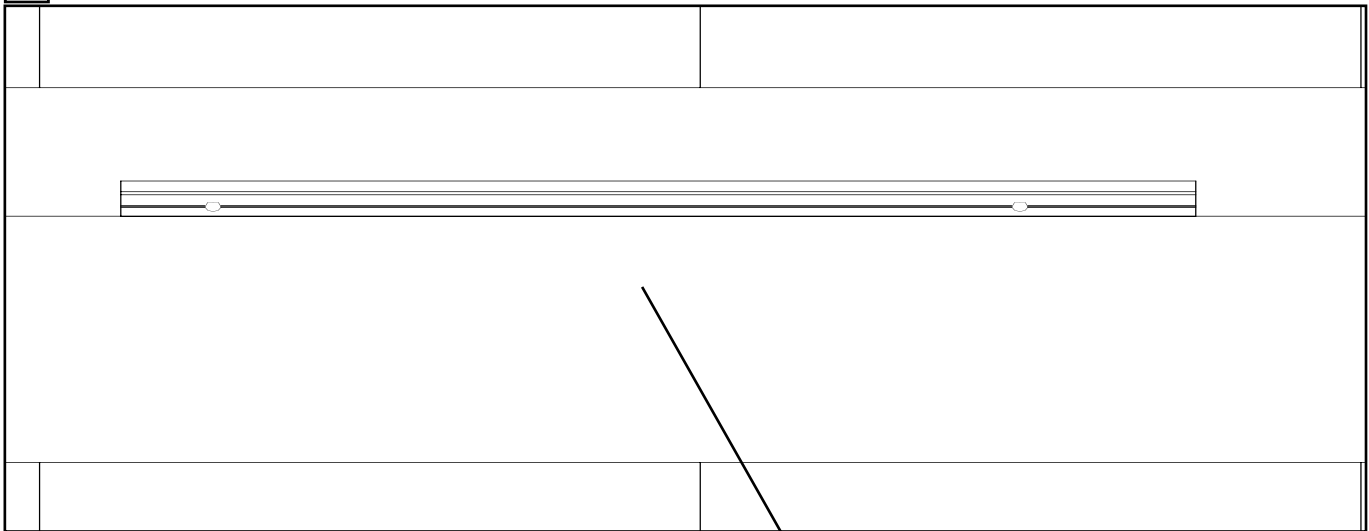

Drill 8 mm holes for wall anchors provided. Insert wall anchors and mount wall bracket as shown in Sketch 8 & 9.

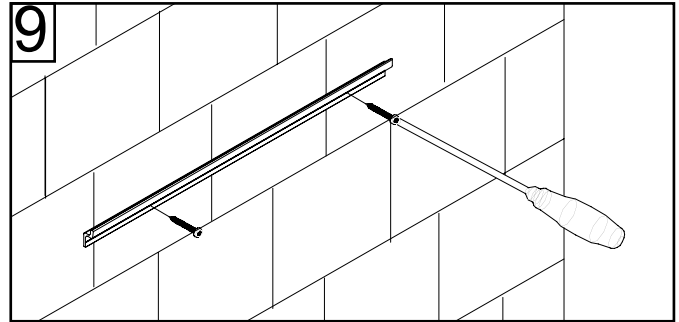
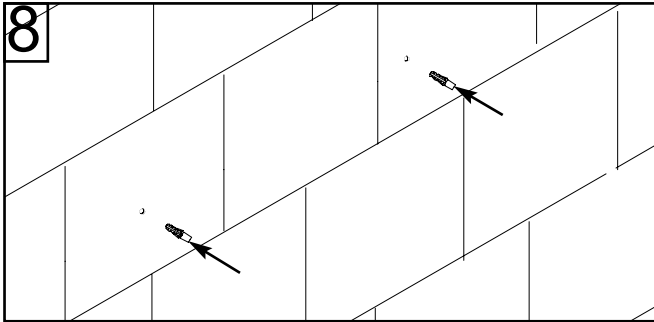

Insert Surface mount Z clips as shown in Sketch 10 & 11

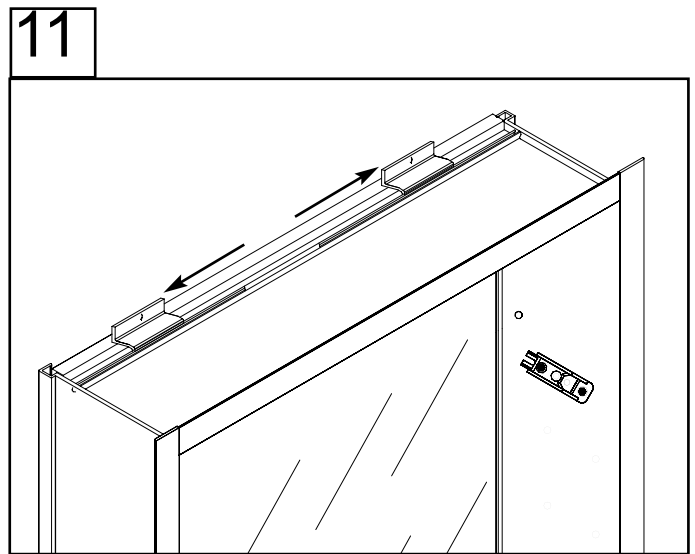
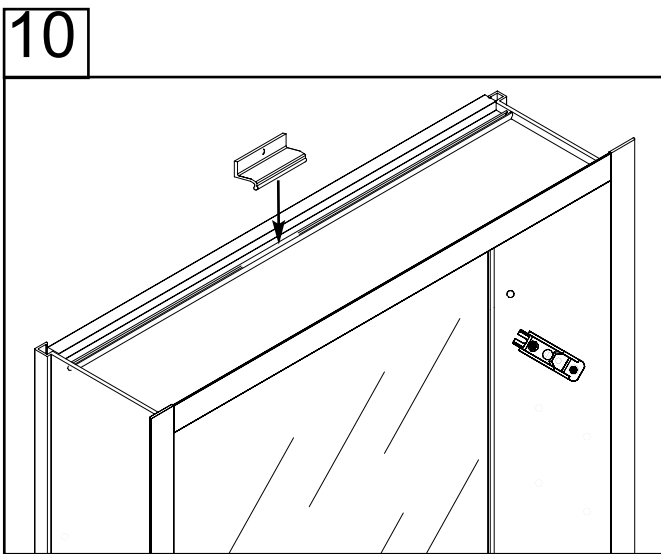

Place Cabinet onto Wall bracket as shown in Sketch's 12 & 13. Mark hole locations of Z clips. Remove Cabinet and drill 8mm holes for Z Clips. Insert wall anchors, remount Cabinet, and attach with screws provided as shown in Sketch 14.

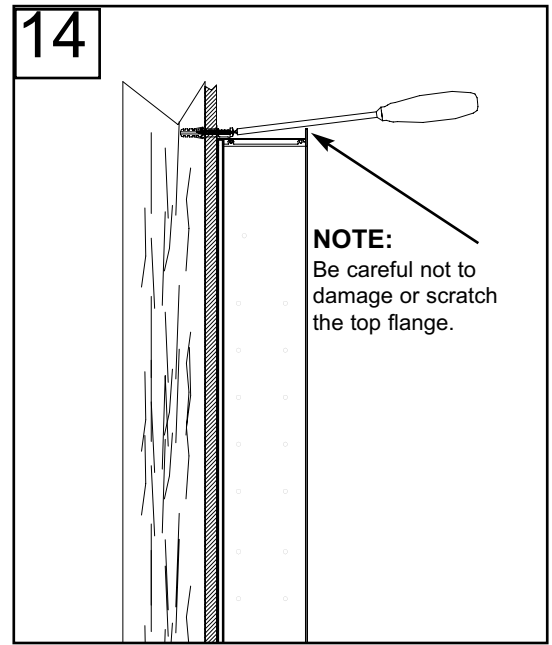
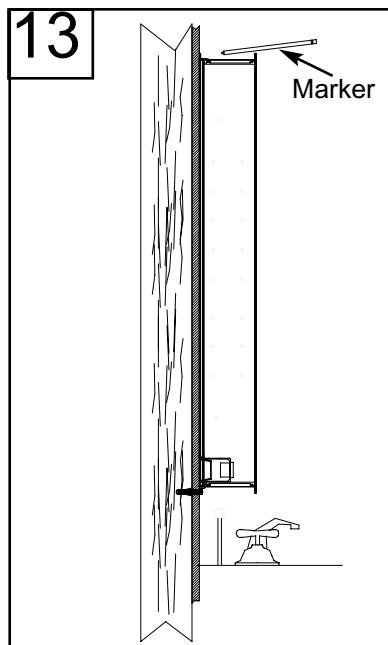
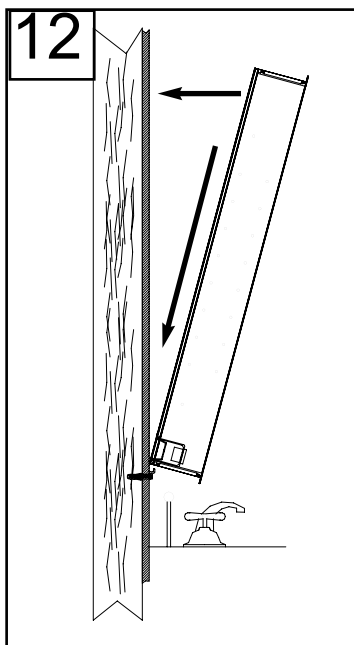

**NOTE:**  
Be careful not to damage or scratch the top flange.

# Cabinet Connector Installation

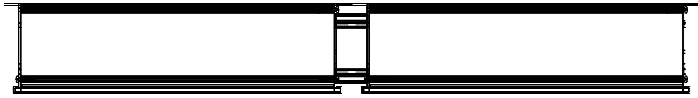

Connect Two or more cabinets together using Cabinet Connectors Part # 11 & 10-32 x 1/2" machine screws Part # 12 as Shown in Sketch 15.

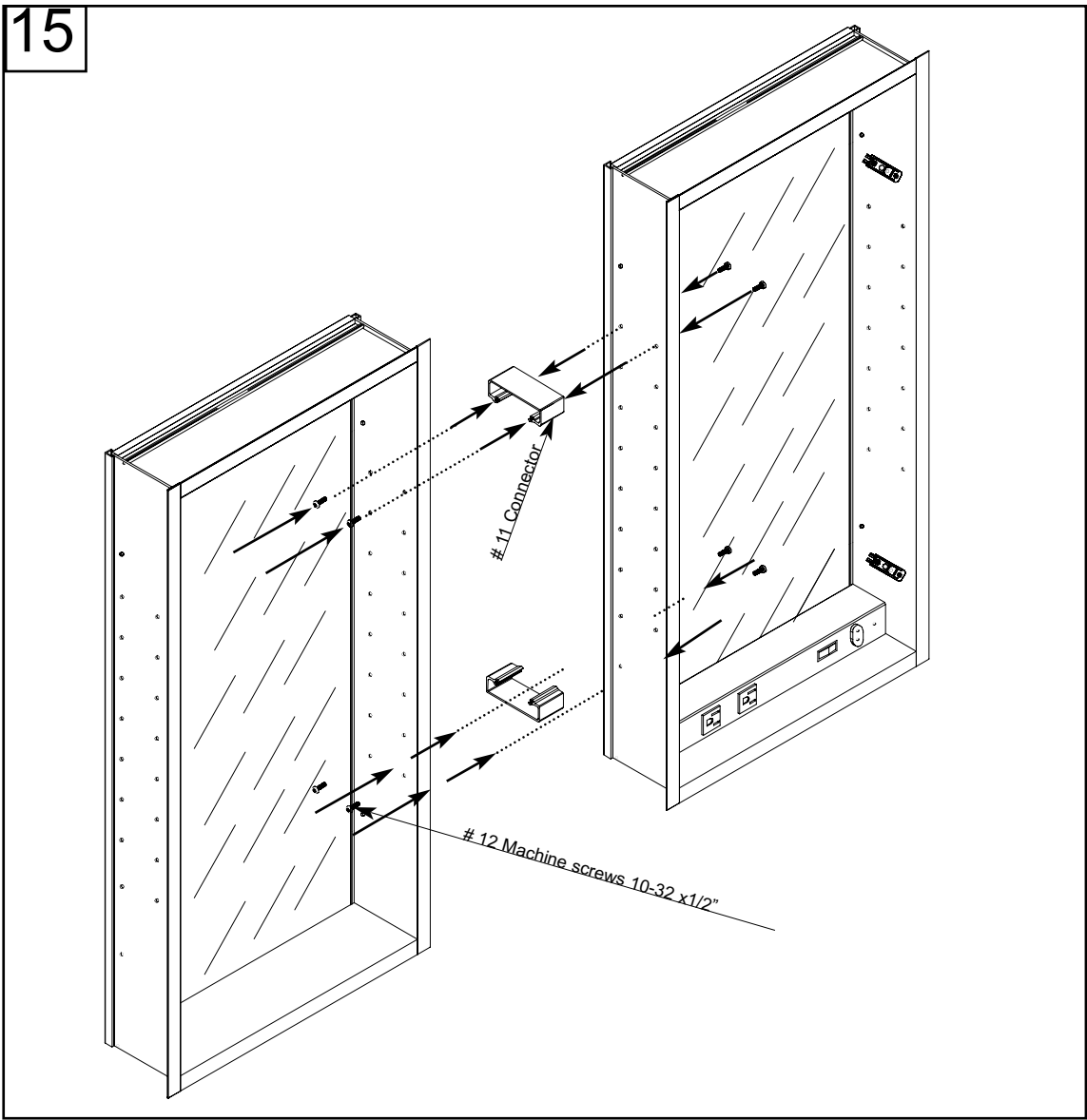
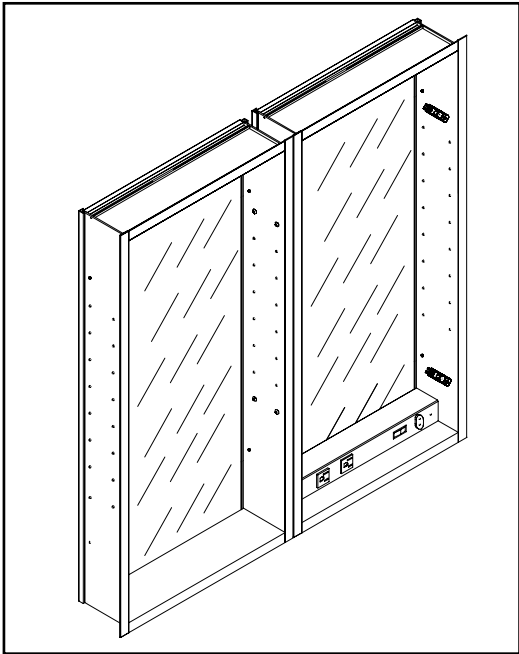

If connecting more than Two (2) cabinets together and you are recessing them, it is recommended that at approximately the center of the combined cabinets that you drill a # 7 hole in the inside top of cabinet and place a # 10 wood screw part # 9 as shown in sketches 16 & 17.

16

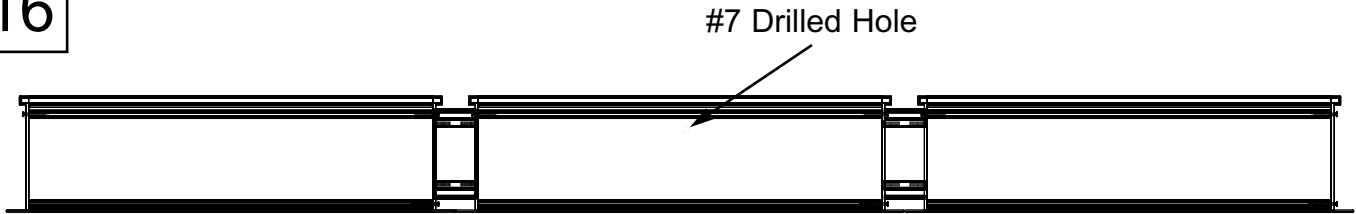

17

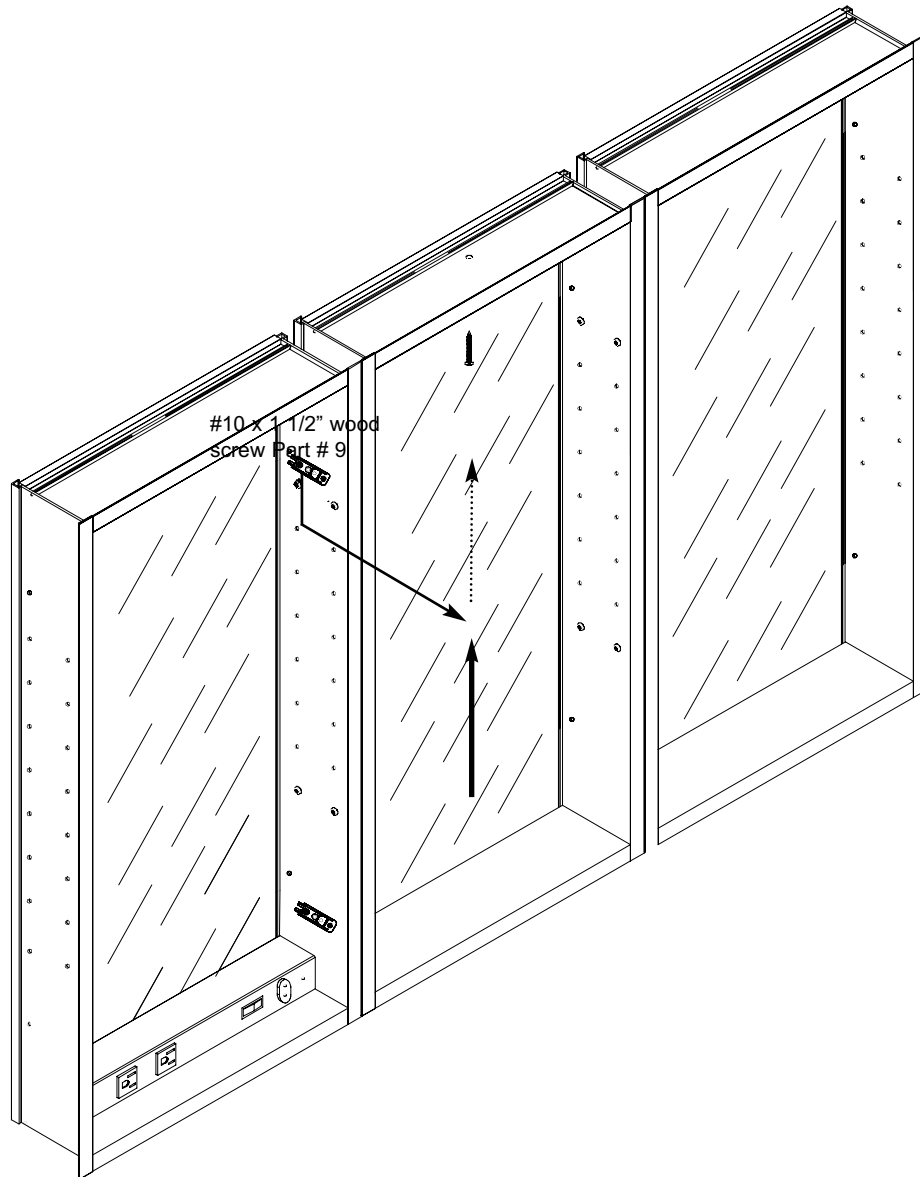

# Side Kit Installation

Using 10-32 x 1/2" Machine screws attach Side Kit Mounting Bracket as shown. Clean back of side kit mirror with alcohol pad then place foam pads to mirror as shown. Peel tape off of Brackets and place Mirrored Side kit as shown. Repeat process for opposite side.

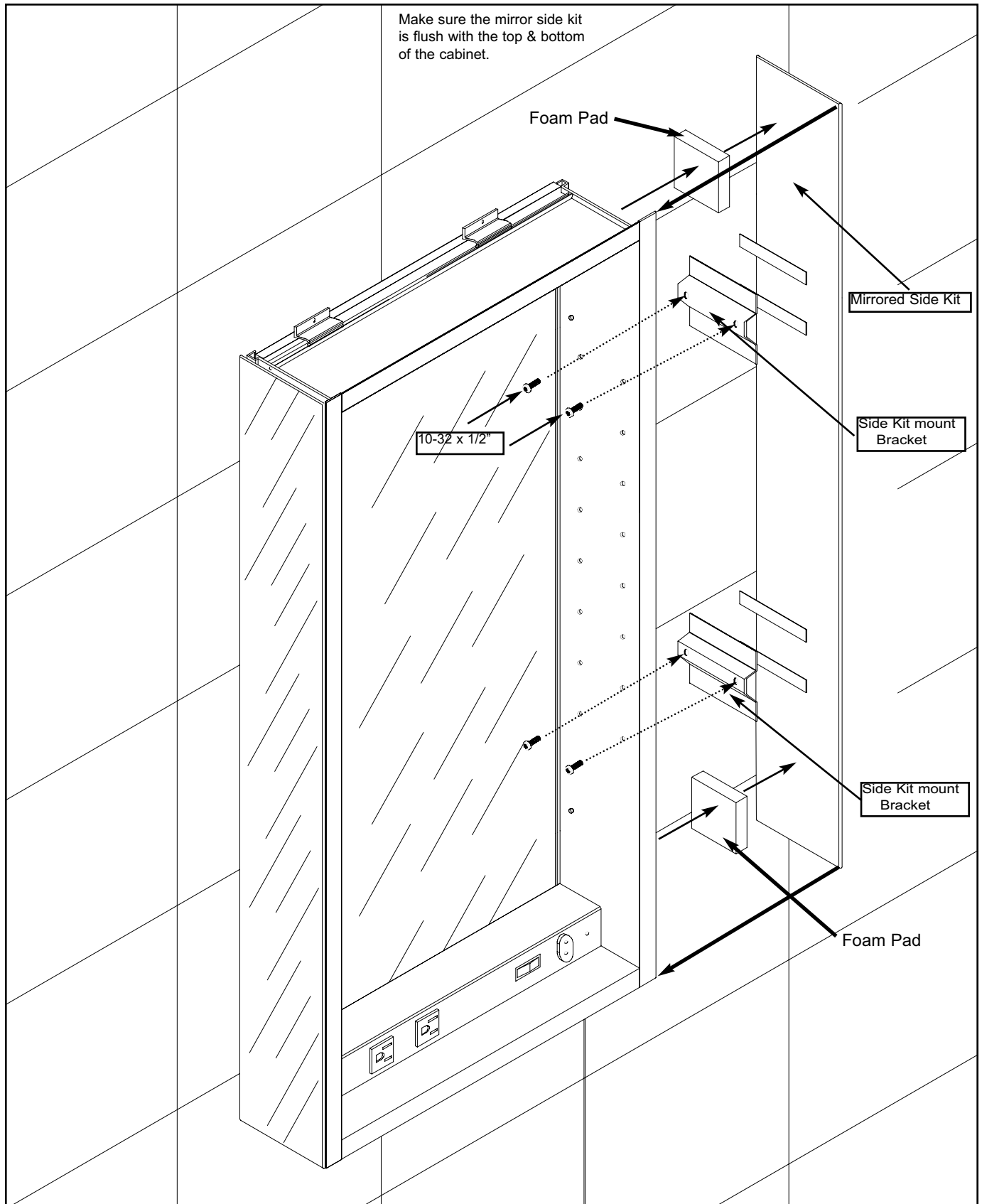

## Door Installation

When Cabinet installation is completed follow instructions on how to install door to cabinet Sketch 18

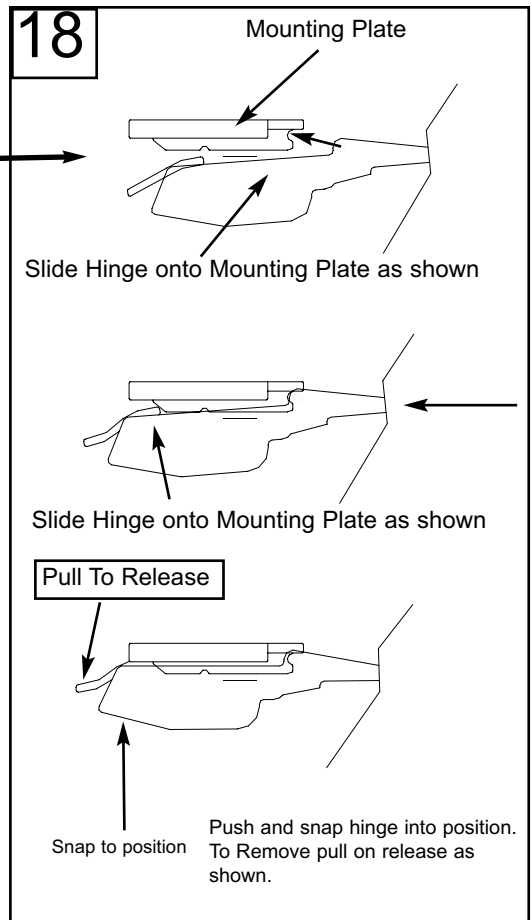
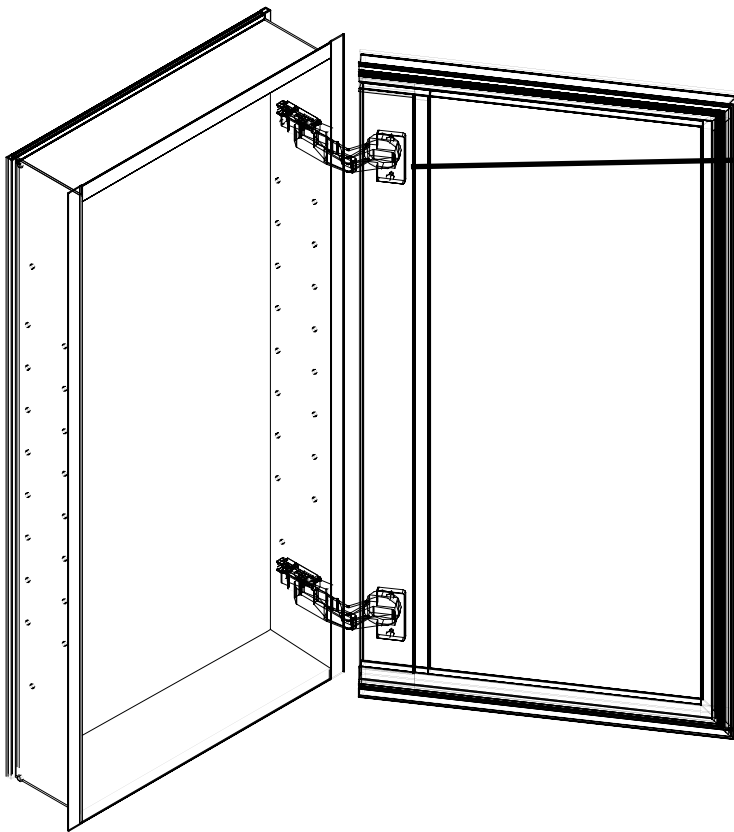

## BLUM Hinge Adjustment

Remove Cover Cap for Hinge Adjustment. Replace Caps when adjustment is completed.

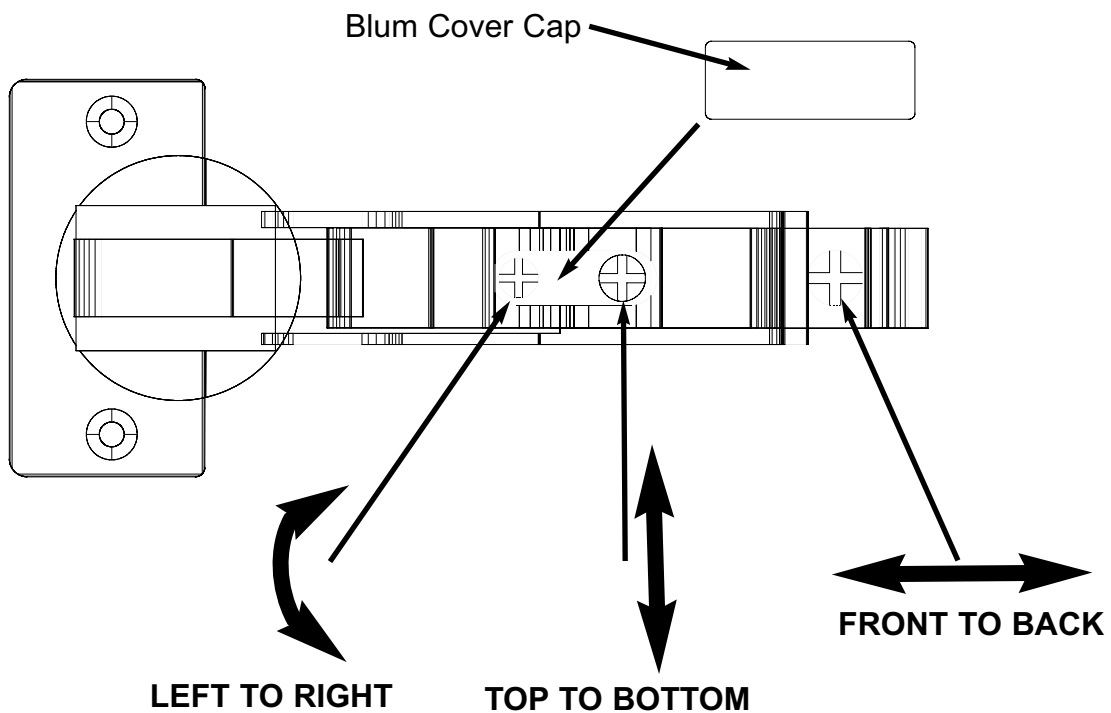

After door and cabinet are installed, Peel Release from Name Plate & Door and Place Name Plates as shown in Sketch 19 & 20

19

20

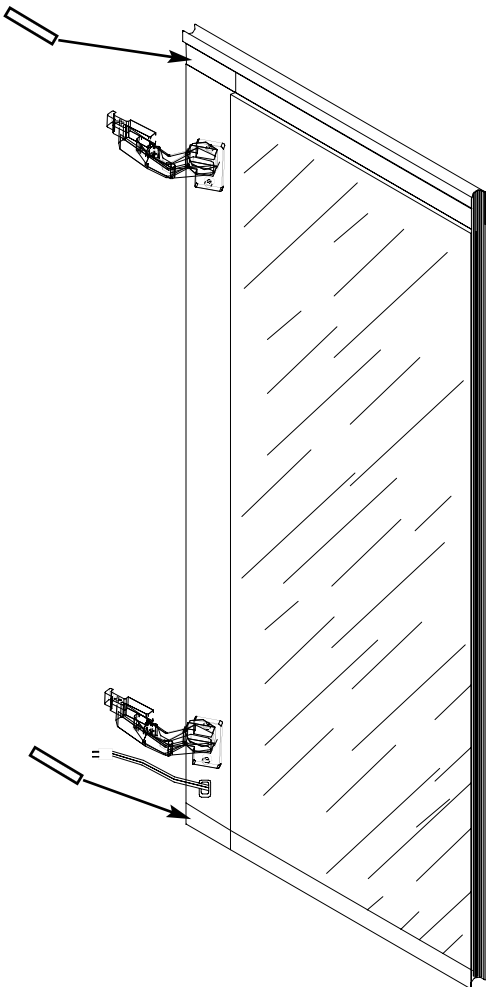
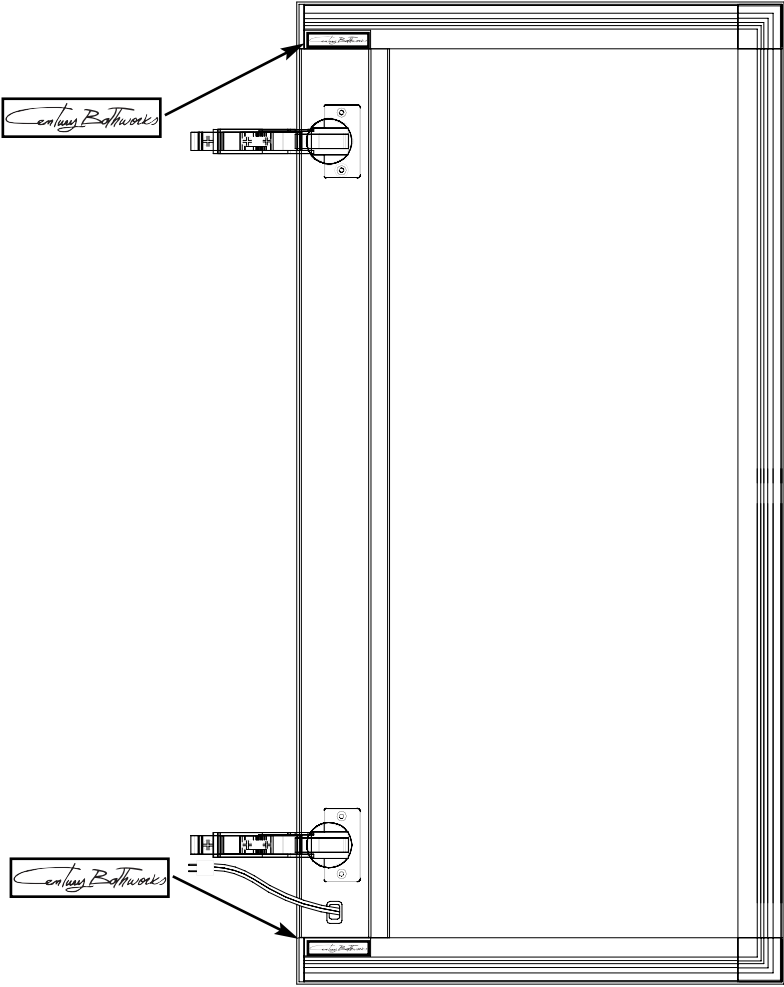

Place 130 Deg limit Clips as Shown in Sketch 21 & 22 If required

22

21

130 Deg Limit Clip

Blum Hinge

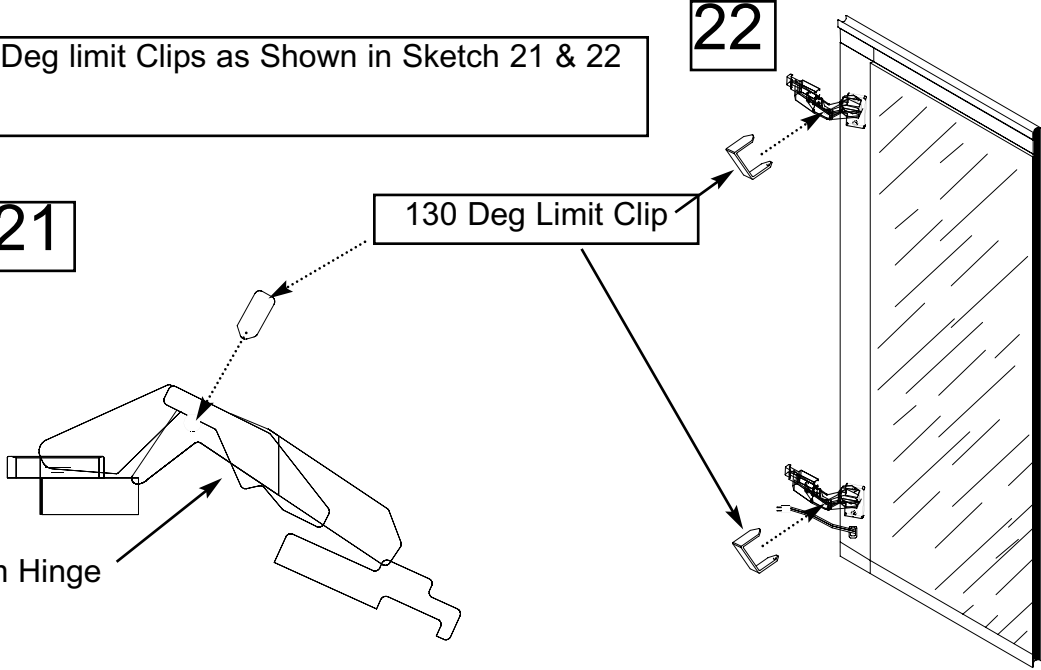

**PARTS LIST-1524 CABINET**

- 1- 1524 Cabinet
- 2- 1524 Door (Note: DO NOT REMOVE DOOR FROM PROTECTIVE CARTON UNTIL INSTALLATION OF DOOR)
- 3- Glass Shelves 5/16" Thick (2)
- 4- Mounting Bracket (For Surface Mount) (1)
- 5- Surface Mount Top Z Clips (2)
- 6- Hole Plugs (20)
- 7- Clear Shelf Clips (8)
- 8- Screw Head Cover Caps (8)
- 9- Wood Screws # 10 x 1 1/2" (5)
- 10- Plastic Wall Anchors (5)
- 11- Cabinet Connectors (2)
- 12- # 10-32 x 1/2" Machine Connector Screws (8)
- 13- Name Plates (2)
- 14- 130 Deg Limit Clips (2)

**PARTS LIST-1530 CABINET**

- 1- 1530 Cabinet
- 2- 1530 Door (Note: DO NOT REMOVE DOOR FROM PROTECTIVE CARTON UNTIL INSTALLATION OF DOOR)
- 3- Glass Shelves 5/16" Thick (3)
- 4- Mounting Bracket (For Surface Mount) (1)
- 5- Surface Mount Top Z Clips (2)
- 6- Hole Plugs (32)
- 7- Clear Shelf Clips (12)
- 8- Screw Head Cover Caps (8)
- 9- Wood Screws # 10 x 1 1/2" (5)
- 10- Plastic Wall Anchors (5)
- 11- Cabinet Connectors (2)
- 12- # 10-32 x 1/2" Machine Connector Screws (8)
- 13- Name Plates (2)
- 14- 130 Deg Limit Clips (2)

**PARTS LIST-1930 CABINET**

- 1- 1930 Cabinet
- 2- 1930 Door (Note: DO NOT REMOVE DOOR FROM PROTECTIVE CARTON UNTIL INSTALLATION OF DOOR)
- 3- Glass Shelves 5/16" Thick (3)
- 4- Mounting Bracket (For Surface Mount) (1)
- 5- Surface Mount Top Z Clips (2)
- 6- Hole Plugs (32)
- 7- Clear Shelf Clips (12)
- 8- Screw Head Cover Caps (8)
- 9- Wood Screws # 10 x 1 1/2" (5)
- 10- Plastic Wall Anchors (5)
- 11- Cabinet Connectors (2)
- 12- # 10-32 x 1/2" Machine Connector Screws (8)
- 13- Name Plates (2)
- 14- 130 Deg Limit Clips (2)

**PARTS LIST-2330 CABINET**

- 1- 2330 Cabinet
- 2- 2330 Door (Note: DO NOT REMOVE DOOR FROM PROTECTIVE CARTON UNTIL INSTALLATION OF DOOR)
- 3- Glass Shelves 5/16" Thick (3)
- 4- Mounting Bracket (For Surface Mount) (1)
- 5- Surface Mount Top Z Clips (2)
- 6- Hole Plugs (32)
- 7- Clear Shelf Clips (12)
- 8- Screw Head Cover Caps (8)
- 9- Wood Screws # 10 x 1 1/2" (5)
- 10- Plastic Wall Anchors (5)
- 11- Cabinet Connectors (2)
- 12- # 10-32 x 1/2" Machine Connector Screws (8)
- 13- Name Plates (2)
- 14- 130 Deg Limit Clips (2)

**PARTS LIST-1540 CABINET**

- 1- 1540 Cabinet
- 2- 1540 Door (Note: DO NOT REMOVE DOOR FROM PROTECTIVE CARTON UNTIL INSTALLATION OF DOOR)
- 3- Glass Shelves 5/16" Thick (4)
- 4- Mounting Bracket (For Surface Mount) (1)
- 5- Surface Mount Top Z Clips (2)
- 6- Hole Plugs (44)
- 7- Clear Shelf Clips (16)
- 8- Screw Head Cover Caps (8)
- 9- Wood Screws # 10 x 1 1/2" (5)
- 10- Plastic Wall Anchors (5)
- 11- Cabinet Connectors (2)
- 12- # 10-32 x 1/2" Machine Connector Screws (8)
- 13- Name Plates (2)
- 14- 130 Deg Limit Clips (3)

**PARTS LIST-1940 CABINET**

- 1- 1940 Cabinet
- 2- 1940 Door (Note: DO NOT REMOVE DOOR FROM PROTECTIVE CARTON UNTIL INSTALLATION OF DOOR)
- 3- Glass Shelves 5/16" Thick (4)
- 4- Mounting Bracket (For Surface Mount) (1)
- 5- Surface Mount Top Z Clips (2)
- 6- Hole Plugs (44)
- 7- Clear Shelf Clips (16)
- 8- Screw Head Cover Caps (8)
- 9- Wood Screws # 10 x 1 1/2" (5)
- 10- Plastic Wall Anchors (5)
- 11- Cabinet Connectors (2)
- 12- # 10-32 x 1/2" Machine Connector Screws (8)
- 13- Name Plates (2)
- 14- 130 Deg Limit Clips (3)

**PARTS LIST-2340 CABINET**

- 1- 2340 Cabinet
- 2- 2340 Door (Note: DO NOT REMOVE DOOR FROM PROTECTIVE CARTON UNTIL INSTALLATION OF DOOR)
- 3- Glass Shelves 5/16" Thick (4)
- 4- Mounting Bracket (For Surface Mount) (1)
- 5- Surface Mount Top Z Clips (2)
- 6- Hole Plugs (44)
- 7- Clear Shelf Clips (16)
- 8- Screw Head Cover Caps (8)
- 9- Wood Screws # 10 x 1 1/2" (5)
- 10- Plastic Wall Anchors (5)
- 11- Cabinet Connectors (2)
- 12- # 10-32 x 1/2" Machine Connector Screws (8)
- 13- Name Plates (2)
- 14- 130 Deg Limit Clips (3)

**Limited One Year Warranty**

Century Bathworks warrants to the original purchaser that, it will, at its election repair, replace, or make appropriate adjustments to products made by this company shown to have significant defects in material or workmanship which are reported to Century Bathworks in writing within one year from the date of delivery. Century Bathworks is not responsible for installation cost.

The warranty is void in the event the product is damaged in transit, or if damage or failure is caused by abuse, misuse, abnormal usage, faulty installation, damage in an accident, improper maintenance, or any repairs other than those authorized by Century Bathworks. At the expiration of the one year warranty period, Century Bathworks shall be under no obligation under any warranty, expressed or implied, including the implied warranty of merchantability.

CENTURY BATHWORKS shall not be liable for any consequential damages arising out of or in connection with the use or performance of its products. Some states do not allow limitations on how long an implied warranty lasts or do not allow the exclusion or limitation of incidental or consequential damages, so the above limitation or exclusion may not apply to you.

Any liability against Century Bathworks under any implied warranty, including the warranty of merchantability, is expressly limited to the terms of this warranty. Permission to return any merchandise under this warranty must be authorized by Century Bathworks and returned prepaid by the purchaser. Claims under this warranty should be sent directly to your dealer.



Century Bathworks, Inc.™  
 250 Lackawanna Ave, West Paterson, NJ 07424  
 973-785-4290 800-524-2578 Fax 973-785 0777  
 www.centurybathworks.com

## Shelf Clip Installation

**Note:** Shelf Holder must be installed before cabinets are installed. Remove existing screws in the cabinet body as shown in Sketch A. Using removed screws Place Shelf Holder into position and insert screws as shown in Sketch B. **(Caution Do Not Overtighten Screws)** Insert Nylon Set Screws as shown in Sketch C.

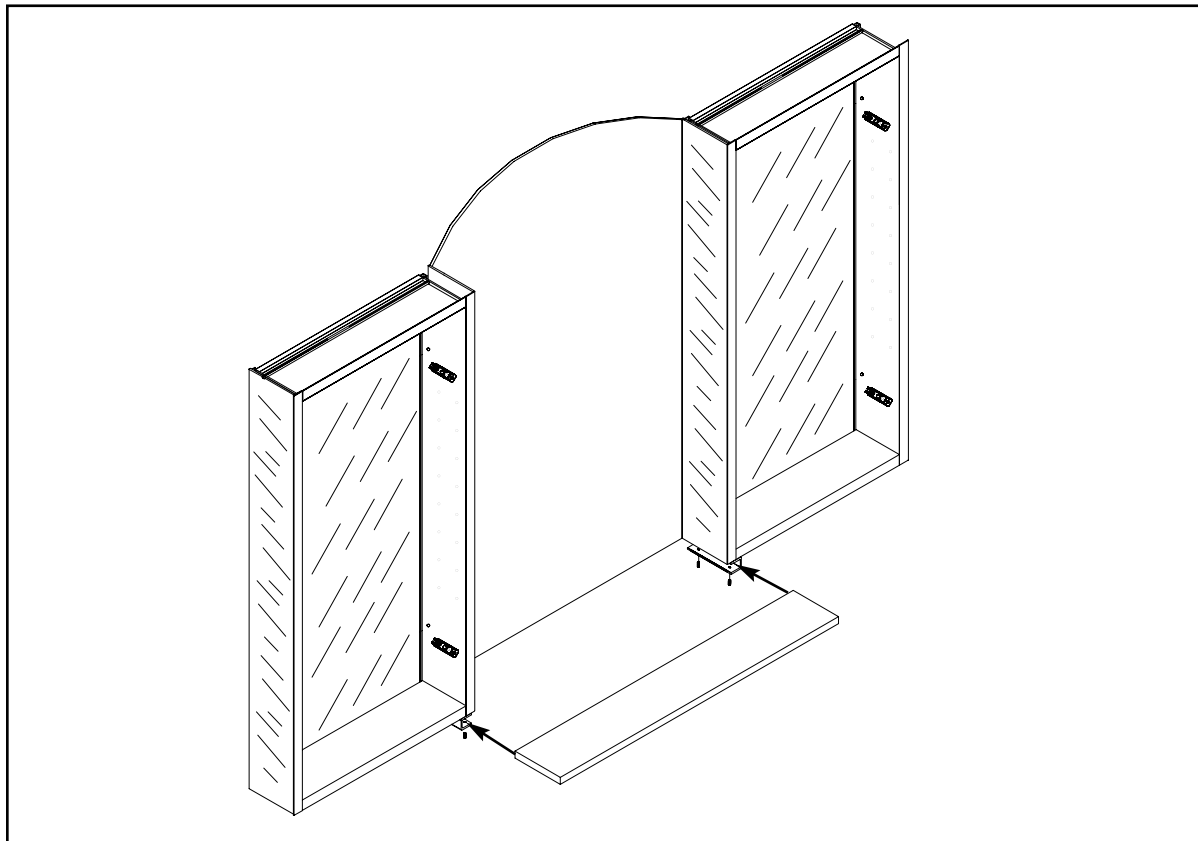
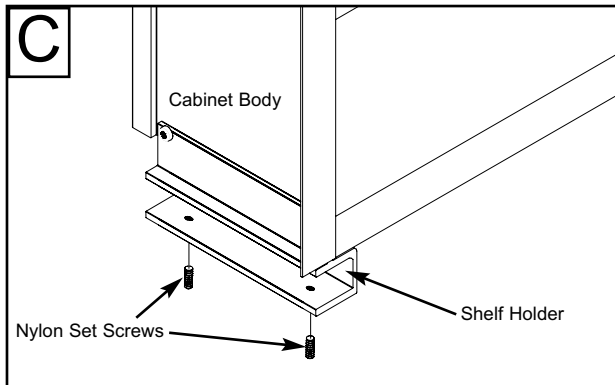
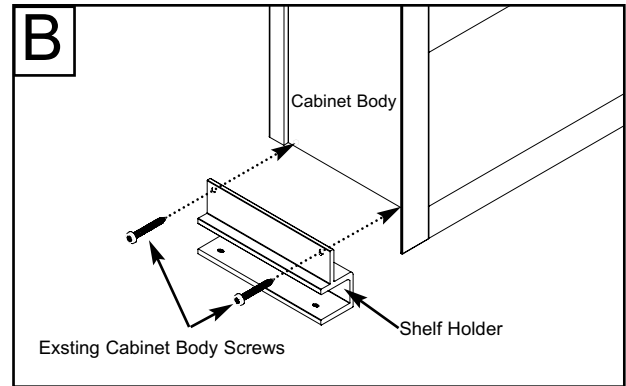
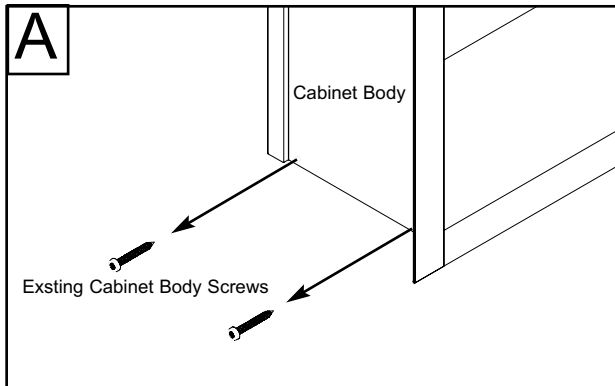

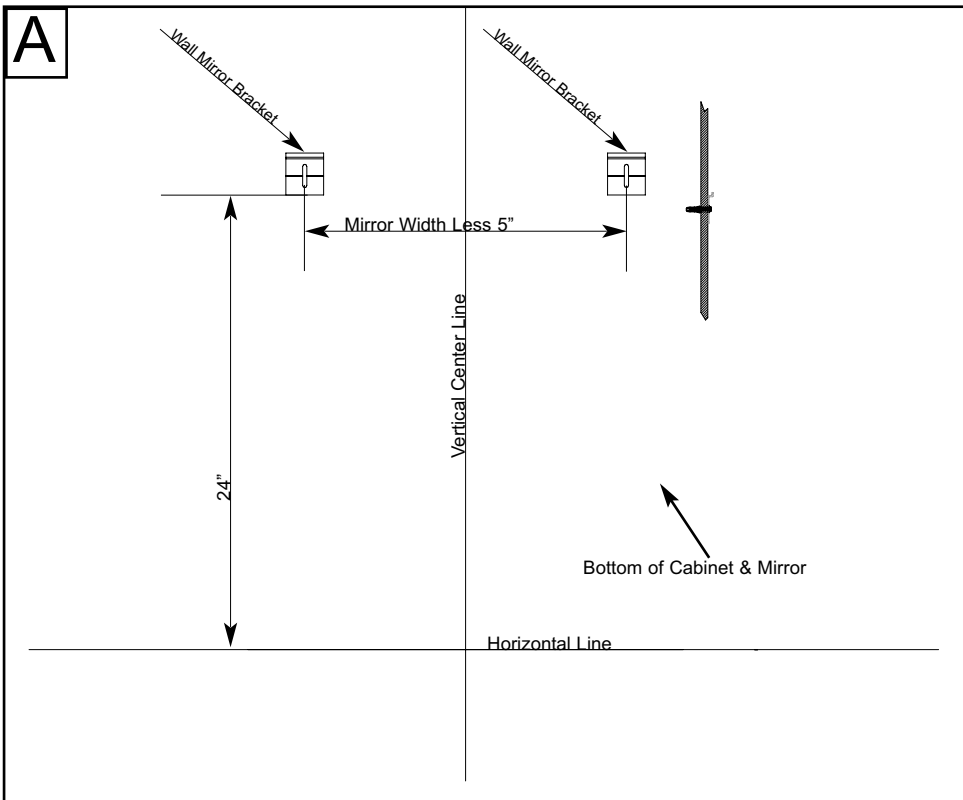
**A****EXAMPLE:**

Two (2) 1530 Cabinets  
 Center mirror is 30" wide.  
 locate vertical center line at  
 center of desired location on  
 wall see Sketch A. **Note:**The  
 bottom of shelf is 13/16" from  
 bottom of desired height see  
 Sketch B. (Make sure to allow  
 enough room for clearance over  
 the faucet. Draw horizontal line  
 at this location see Sketch A.  
 Place the Two Wall Mirror  
 Brackets as shown in Sketch A

**B**